



**VARRON**

**PRODUCT CATALOGUE**

**2026**

**Varron Autokast Limited**

An IATF 16949:2016 / ISO 9001:2015 Certified Company

**WE MANUFACTURE WITH INNOVATION, PRECISION & TRUST**



## Aluminium Extrusion Plant

The Aluminium Extrusion Plant at Varron Autokast Ltd. has a total production capacity of 36,000 TPA. It is equipped with advanced extrusion presses from SMS and JLM, designed to deliver precise and consistent aluminium profiles for a range of industrial and structural applications.

### Equipment

10 MN & 18 MN Presses (SMS Make) 43 MN Press (JLM Make) All presses are fully automatic and PLC-controlled, ensuring high accuracy, uniformity, and surface finish in every extrusion.

### Alloy Range & Tempers

Supports alloys from the 1000 to 7000 series  
Available tempers: T4, T5, and T6.

### Applications & Capabilities

Used in building and construction, furniture, automotive, and industrial components Capable of producing a wide variety of profiles — from common industrial sections to complex, ultra-thin, and lightweight designs Consistent quality with optimized lead times through efficient manufacturing Process.

## TABLE OF CONTENTS

<i>Alloy Specification</i> .....	1
<i>Chemical Composition</i> .....	3
<i>Wrought Alloys: Guide To Selection</i> .....	4
<i>Flat Bars</i> .....	5
<i>Flat Bars With Corner Radius</i> .....	6
<i>Flat Bar With Full Radius</i> .....	7
<i>Equal Angles</i> .....	8
<i>Unequal Angles</i> .....	9
<i>U-Channels</i> .....	10
<i>Round Bars</i> .....	11
<i>Square Bars</i> .....	13
<i>Hex Bar</i> .....	14
<i>Square Tubes</i> .....	15
<i>Rectangular Tubes</i> .....	16
<i>Round Tubes</i> .....	17
<i>IPS Tubes</i> .....	19
<i>T - Sections</i> .....	20
<i>H – Sections</i> .....	21
<i>Furnitures</i> .....	22
<i>Minimal Glass Adapter</i> .....	24
<i>Doors &amp; Partition</i> .....	25
<i>Sliding Window</i> .....	26
<i>18 mm Series</i> .....	26
<i>25 mm Series</i> .....	28
<i>20 X 54 Sliding</i> .....	29
<i>27 X 65 Domal Series</i> .....	30
<i>27 X 65 Lite Series</i> .....	30
<i>29 mm Series</i> .....	31
<i>37 mm Opulence</i> .....	31
<i>Casement Series</i> .....	33
<i>45 mm Unitised Casement</i> .....	33
<i>45 mm Casement</i> .....	34
<i>50 mm Series</i> .....	35

---

<i>Glazing Clips</i> .....	37
<i>Transport Section</i> .....	38
<i>Solar Sections</i> .....	40
<i>Architectural Miscellaneous</i> .....	41
<i>Industrial Miscellaneous</i> .....	42
<i>Actuators</i> .....	42
<i>Ladder Section</i> .....	43
<i>Tent Profile</i> .....	45
<i>Curtain Walls</i> .....	46
<i>120 mm Curtain Walls</i> .....	47
<i>Sleek Curtain Walls</i> .....	48
<i>186 mm Curtain Series</i> .....	49
<i>Semi-Unitised Curtain Walls</i> .....	50
<i>Brackets</i> .....	52
<i>Form Work</i> .....	53
<i>Certifications</i> .....	55

---

## ALLOY SPECIFICATION

ALLOY EQUIVALENTS TABLE								
IS India (NEW)	(BS) U.K (OLD) or I.S.	(AA) U.S. A	(AICAN) Canada	DIN Germany	ASTM	(JIS) Japan	(AFNOR) France	Russia
19500	E1B	1050 or 1060	IS	Al 99.5	99.6 A	Al-1	A-5	-
19000	E1C	1100	2S	Al 99.0	99.0A	Al-3	A-4	A-2
19501	E1E	EC	CISDIA	E-Al 99.5	EC	Al-1	-	-
63401	E91E	6101	D50S	E-Al-Mg-Si-o.5	GS 10B	-	-	-
-	NE-3	3103	3S	Al Mn	-	-	3103	-
52000	NE4	5052	M57S	AlMg2	GR 20A	A2-SI	A-G3	AM
53000	NE5	5086	54S	AlMg3.5	GM 40A	-	-	-
63400	HE-9	6063	50S	Al Mg Si 0.5	GS 10A	A2-S5	A-SG	-
24345	HE-15	2014	B26S	Al-Cu-Si	-	-	-	-
76528	HE-17	7075	-	AlZn5, 5MgCu	7075	A7075	7075	-
65032	HE-20	6061	65S	Al Mg Si Cu	GS11A	A2-S4	-	-
64430	HE-30	6351/6082	B51S	Al Mg Si1	6351	-	6081 (NP)	-
62400	-	6005	C51S	-	6005	-	-	-
64423	-	-	C62S	-	-	-	-	-
-	-	-	6262	-	AlMg1 SiPb	6262	-	-

TEMPER DESIGNATION TABLE			
INDIA or U. K	U.S.A or CANADA	ISO TEMPER	Description of designation
O	O	O	Annealed
M	F	F	As fabricated, as manufactured or as cast
-	T3	TD	Solution heat-treated, and cold worked
W	T4	TB	Solution heat-treated, naturally aged and amenable to artificial ageing
P	T5	TE	Artificially aged or precipitation heat-treated
WP	T6	TF	Solution heat-treated & precipitation heat-treated

<u>Non - Heat Treatable Alloys</u>					
Alloy AA Old (ISS) New (ISS)	Temper	Ultimate Tensile Strength MPa		0.2% Proof Stress MPa	Elongation On 50 mm GL
		Min.	Max.		
1100[1C][19000]	O	-	108	-	25
1050[1B][19500]	O	-	98	-	25
1060[19600]	O	-	93	-	25
1070[19700]	O	-	93	-	25
4043[N21][43000]	O	-	128	-	18
4047[N2] [46000]	O	-	147	-	12
5052[N4] [52000]	O	-	240	-	18
5086[N5] [53000]	O	-	260	-	16
5056[N6] [55000]	O	-	338	-	15
5083[N8] [54300]	O	-	348	-	13

<u>Heat Treatable Alloys</u>					
2014 [H15] [24345]	T4[W] T6 [WP]	383 481	- -	235 422	10 6
2017 [H14] [24534]	T4[W]	383	-	235 0	10
6063 [H9] [63400]	T4[W] T6 [WP]	137 186	- -	78 152	14 7
6061 [H20] [65032]	M or O T4[W] T6 [WP]	- 186 280	147 - -	- 113 235	16 14 7
6351[H30] [64430]	M or O T4[W] T6 [WP]	- 186 309	147 - -	- 118 270	16 14 7
6066	O T4[W] T6 [WP]	- 275 343	201 - -	- 172 309	16 14 7
6101[91E] [63401]	T4[W] T6 [WP]-Range1 T6 [WP]-Range2	137 170 201	- - -	78 135 167	12 12 10
6201 [64401]	T4[W] T8 [WDP]	157 314	- -	69 -	14 3
7039 [74530]	T4[W] T6 [WP]	275 309	- -	231 260	9 7
7075	T6 [WP]	530	-	456	6

## CHEMICAL COMPOSITION

ALLOY	% Si	% Mg	% Mn	% Cu	% Fe	% Cr	% Zn	% Ti	% OTHERS	% Al
EN AW-1050 A	0.25Max	0.05Max	0.05Max	0.05Max	0.40Max	–	0.07Max	0.05Max	–	99.5 Min
EN AW-1070 A	0.20Max	0.03Max	0.03Max	0.03Max	0.25Max	–	0.07Max	0.03Max	–	99.7 Min
EN AW-1100	Si+Fe 0.95 Max	–	0.05 Max	0.05 – 0.20	–	–	0.10 Max	0.05 Max	–	99.0 Min
EN AW-2011**	0.40 Max	–	–	5.00 – 6.00	0.70 Max	–	0.30 Max	–	Bi : 0.20 – 0.60 Pb : 0.20 – 0.60	Bal.
EN AW-2111	0.40 Max	-	-	4.5-6.00	0.70 Max	-	0.30 Max	–	Bi : 0.5 – 0.80 Sn : 0.15 – 0.35 Pb : 0.05 Max	Bal.
EN AW-2017A**	0.20 – 0.80	0.40 – 1.0	0.40 – 1.0	3.50 – 4.5	0.70 Max	0.10 Max	0.25 Max	0.15 Max	–	Bal.
EN AW-2014**	0.50 – 1.20	0.20 – 0.80	0.40 – 1.20	3.90 – 5.00	0.70 Max	0.10 Max	0.25 Max	0.15 Max	–	Bal.
EN AW-2024**	0.50 Max	1.20 -1.80	0.30 – 0.90	3.80 – 4.90	0.50 Max	0.10 Max	0.25 Max	0.15 Max	0.15 Max	Bal.
EN AW-3003	0.60 Max	–	1.00 – 1.50	0.05 – 0.20	0.70 Max	–	0.10 Max	–	0.15 Max	Bal.
EN AW-3103	0.50 Max	0.30 Max	0.90 – 1.50	0.10 Max	0.70 Max	0.10 Max	0.20 Max	0.10 Max	–	Bal.
EN AW-5083**	0.40 Max	4.0 - 4.90	0.40 - 1.00	0.10 Max	0.40 Max	0.05 - 0.25	0.25 Max	0.15 Max	0.15 Max	Bal.
EN AW-6101B	0.30 – 0.7	0.40 – 0.90	0.03 Max	0.05 Max	0.40 Max	–	–	–	0.10 Max	Bal.
EN AW-6005	0.60 – 0.90	0.40 – 0.60	0.10 Max	0.10 Max	0.35 Max	0.10 Max	0.10 Max	0.10 Max	–	Bal.
EN AW-6005A	0.50 - 0.90	0.40 - 0.70	0.50 Max	0.30 Max	0.35 Max	0.30 Max	0.20 Max	0.10 Max	0.15 Max	Bal.
EN AW-6351	0.70 – 1.30	0.40 – 0.80	0.40 – 0.80	0.10 Max	0.50 Max	–	0.20 Max	0.20 Max	0.15 Max	Bal.
EN AW-6060	0.30 – 0.60	0.35 – 0.60	0.10 Max	0.10 Max	0.10 – 0.30	0.05 Max	0.15 Max	0.10 Max	–	Bal.
EN AW-6061	0.40 – 0.80	0.80 – 1.20	0.15 Max	0.15 – 0.40	0.70 Max	0.04 – 0.35	0.25 Max	0.15 Max	–	Bal.
EN AW-6063	0.20 – 0.60	0.45 – 0.90	0.10 Max	0.10 Max	0.35 Max	0.10 Max	0.10 Max	0.10 Max	–	Bal.
EN AW-6082	0.70 – 1.30	0.60 -1.20	0.40 – 1.00	0.10 Max	0.50 Max	0.25 Max	0.20 Max	0.10 Max	–	Bal.

## WROUGHT ALLOYS: GUIDE TO SELECTION

Alloy	Temper	Resistance to Corrosion	Workability (Cold)	Machinability	Braze ability	Weldability	Commonly available forms.	Indications of use
2014 (H 15) (24345)	T4	C	C	B	D	C	Rods Bars	Highly stressed component of all types in aircraft, ordnance and general engineering
	T6	C	D	B	D	C		
5086 (N 5) (53000)	O, F	A	A	D	D	A	Flats, Rods & other sections	Ship building and other marine applications, rivets, coinage etc.
6061 (H 20) (65032)	O, F	A	A	D	A	A	Rods, Flats, Tubes & other sections	Heavy duty structures, building hardware, sections for bus body, truck and rail coach, furniture, rivets etc.
	14	A	C	C	A	A		
	T6	A	D	C	A	A		
6063 (H9)	O, F	A	A	D	A	A	Rods, Flats, Tubes & other sections	Building hardware, architectural sections with good surface finish, medium strength furniture and anodized sections.
	14	A	B	C	A	A		
	T6	A	C	C	A	A		
	T5	A	C	C	A	A		
6066 (22450)	O, F	B	B	D	A	A	Rods and other solid sections	For welded structures, textile parts, heavy duty machine parts.
	14	B	C	B	A	A		
	T6	B	C	8	A	A		
6101 (91 E) (63401)	14	A	B	C	A	A	Rods, Flats, Tubes & other sections	High strength electrical busbar sections.
	16	A	B	C	A	A		
6201 (64401)	T4	A	A	C	A	A	Redraw Rod	Overhead conductors, ACAR and AAAC.
6351 (H 30) (64430)	O, F	A	A	D	A	A	Rods, Flats, Tubes	Structural and general
	T4	A	C	C	A	A		

## FLAT BARS

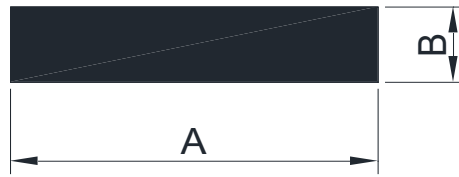

Sr. No.	Section No.	A	B	Kg/Mtr.	Kg/12 Ft
1	01005	19.00	2.00	0.103	0.38
2	01006	19.00	3.00	0.154	0.56
3	01007	25.00	3.00	0.203	0.74
4	01013	50.00	3.00	0.405	1.48
5	01020	50.00	6.00	0.809	2.96
6	01021	75.00	6.00	1.214	4.44
7	01038	88.90	2.50	0.520	1.90
8	01040	110.00	30.00	8.900	32.55

## FLAT BARS WITH CORNER RADIUS

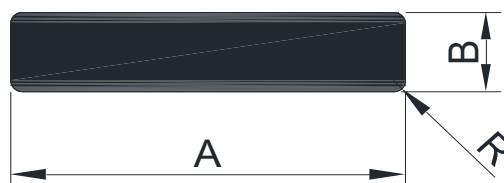

Sr. No.	Section No.	A	B	R	Kg/Mtr.	Kg/12 Ft
1	01022	20.00	6.00	2.0	0.315	1.15
2	01023	25.00	6.00	2.0	0.396	1.45
3	01024	25.00	10.00	2.0	0.666	2.44
4	01025	40.00	6.00	2.0	0.639	2.34
5	01026	40.00	10.00	2.0	1.071	3.92
6	01027	50.00	10.00	2.0	1.341	4.90
7	01028	60.00	10.00	2.0	1.611	5.89
8	01029	65.00	10.00	2.0	1.746	6.39
9	01030	75.00	10.00	2.0	2.016	7.37
10	01031	80.00	6.00	2.0	1.287	4.71
11	01032	80.00	10.00	2.0	2.151	7.87
12	01033	100.00	10.00	2.0	2.691	9.84
13	01034	125.00	10.00	2.0	3.366	12.31
14	01017	192.00	22.00	3.0	11.384	41.64
15	01035	200.00	10.00	2.0	5.391	19.72
16	01041	150.00	25.00	2.0	10.123	37.03
17	01042	150.00	75.00	2.0	30.366	111.07
18	01044	160.00	3.00	2.0	1.295	4.74
19	01046	270.00	22.00	2.0	16.029	58.63
20	01045	340.00	22.00	2.0	20.187	73.84

## FLAT BAR WITH FULL RADIUS

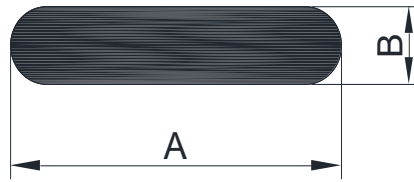

Sr. No.	Section No.	A (mm)	B (mm)	Kg/Mtr.	Kg/12 Ft
1	01008	25.00	5.00	0.323	1.18
2	01009	25.00	10.00	0.617	2.26
3	01010	30.00	10.00	0.752	2.75
4	01011	40.00	5.00	0.526	1.92
5	01002	40.00	6.00	0.627	2.29
6	01012	40.00	10.00	1.022	3.74
7	01018	50.00	6.00	0.789	2.89
8	01001	50.00	10.00	1.292	4.73
9	01039	60.00	6.00	0.951	3.48
10	01014	80.00	10.00	2.102	7.69
11	01003	100.00	10.00	2.642	9.66
12	01015	125.00	10.00	3.317	12.13
13	01016	150.00	10.00	3.992	14.60
14	01004	210.00	12.00	6.721	24.58

## EQUAL ANGLES

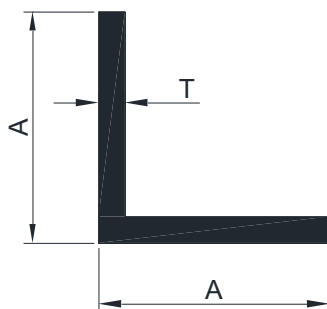

Sr. No.	Section No.	A (mm)	A (mm)	Kg/Mtr.	Kg/12 Ft
1	02019	19.05	1.70	0.167	0.61
2	02017	25.00	1.85	0.241	0.88
3	02029	25.00	2.00	0.259	0.95
4	02003	30.00	3.00	0.461	1.69
5	02018	31.75	2.20	0.364	1.33
6	02016	32.00	2.95	0.486	1.78
7	02020	32.00	2.98	0.491	1.80
8	02007	38.10	2.50	0.497	1.82
9	02021	50.00	2.90	0.760	2.78
10	02013	60.00	2.00	0.637	2.33
11	02014	63.00	3.00	0.996	3.64
12	02015	75.00	2.70	1.074	3.93

## UNEQUAL ANGLES

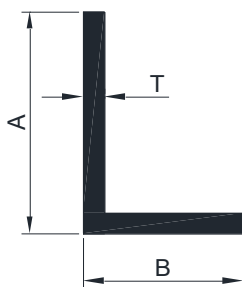

Sr. No.	Section No.	A	B	T	Kg/Mtr.	Kg/12 Ft
1	03004	31.75	19.05	3.18	0.399	1.46
2	03001	38.10	25.40	1.82	0.303	1.11
3	03002	38.10	25.40	2.20	0.364	1.33
4	03003	38.10	25.40	3.00	0.490	1.79

## U-CHANNELS

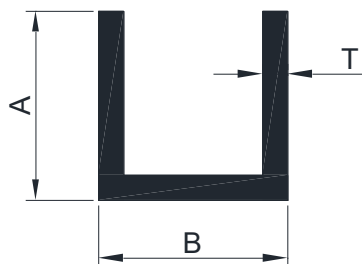

Sr. No.	Section No.	A	B	T	Kg/Mtr.	Kg/12 Ft
1	04002	12.00	19.00	2.10	0.259	0.95
2	04001	40.00	20.00	1.80	0.371	1.36
3	04003	44.45	25.40	3.18	0.925	3.38

## ROUND BARS



Sr. No.	Section No.	φ A	Kg/Mtr.
1	96001	6.00	0.076
2	96005	16.50	0.577
3	96006	18.00	0.687
4	96046	24.30	1.252
5	96007	25.00	1.325
6	96008	26.50	1.489
7	96009	28.50	1.722
8	96014	32.00	2.171
9	96010	32.50	2.240
10	96018	36.00	2.748
11	96027	39.00	3.225
12	96028	39.70	3.342
13	96011	40.00	3.393
14	96029	40.90	3.547
15	96030	42.00	3.741
16	96031	42.86	3.895
17	96076	43.20	3.958
18	96047	43.80	4.068
19	96032	44.00	4.105
20	96033	44.70	4.237
21	96021	45.00	4.294
22	96034	45.50	4.390
23	96035	46.80	4.645
24	96022	48.00	4.886
25	96023	50.00	5.301
26	96024	51.75	5.679
27	96048	52.00	5.734
28	96077	55.00	6.415
29	96049	56.00	6.650
30	96051	58.00	7.134

Sr. No.	Section No.	φ A	Kg/Mtr.
31	96025	58.80	7.332
32	96026	60.00	7.634
33	96036	62.00	8.151
34	96072	63.00	8.417
35	96050	65.00	8.959
36	96037	66.75	9.448
37	96042	72.00	10.993
38	96044	75.00	11.928
39	96045	76.20	12.313
40	96052	80.00	13.572
41	96053	83.00	14.609
42	96054	90.00	17.177
43	96055	100.00	21.206
44	96056	102.00	22.062
45	96057	105.00	23.379
46	96058	110.00	25.659
47	96078	111.00	26.128
48	96059	115.00	28.045
49	96074	117.00	29.029
50	96060	120.00	30.536
51	96075	125.00	33.134
52	96079	127.00	34.203
53	96061	130.00	35.838
54	96062	133.00	37.511
55	96080	135.00	38.647
56	96063	140.00	41.563
57	96064	143.00	43.364
58	96081	145.00	44.585
59	96065	150.00	47.713
60	96066	153.00	49.641



Sr. No.	Section No.	$\varnothing A$	Kg/Mtr.
61	96082	155.00	50.947
62	96067	160.00	54.287
63	96083	165.00	57.733
64	96068	170.00	61.285
65	96084	175.00	64.943
66	96069	180.00	68.707
67	96085	185.00	72.577
68	96086	190.00	76.553
69	96087	200.00	84.823
70	96070	203.00	87.387
71	96088	205.00	89.117
72	96089	208.00	91.745
73	96090	211.00	94.410
74	96091	215.00	98.024
75	96092	220.00	102.636
76	96093	230.00	112.178
77	96094	235.00	117.109
78	96071	245.00	127.288
79	96095	254.00	136.811
80	96096	264.00	147.796
81	96097	268.00	152.308
82	96098	270.00	154.590
83	96099	280.00	166.253
84	96100	285.00	172.244

## SQUARE BARS

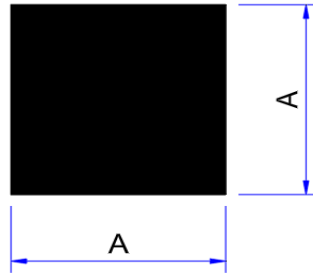

Sr. No.	Section No.	A	R	Kg/Mtr.	Kg/12 Ft
1	07001	8.00	-	0.172	0.629
2	07002	10.00	-	0.268	0.980
3	07010	17.00	-	0.780	2.853
4	07004	20.00	-	1.080	3.950
5	07005	25.00	-	1.688	6.174
6	07006	25.50	-	1.756	6.423
7	07007	30.00	-	2.430	8.888
8	07008	32.00	-	2.765	10.113
9	07009	38.10	-	3.919	14.334
10	07011	80.00	1.00	17.278	63.196
11	07012	101.00	1.00	27.540	100.730
12	07013	110.00	1.00	32.668	119.486
13	07014	116.00	1.00	36.329	132.877
14	07015	125.00	1.20	42.184	154.292
15	07016	150.00	1.50	60.745	222.181
16	07017	180.00	2.00	87.471	319.934

## HEX BAR

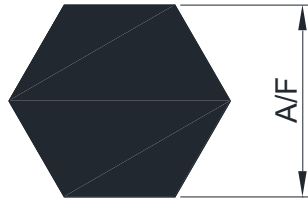

Sr. No.	Section No.	A/F	Kg/Mtr.	Kg/12 Ft
1	21001	15.6	1.705	6.24

## SQUARE TUBES

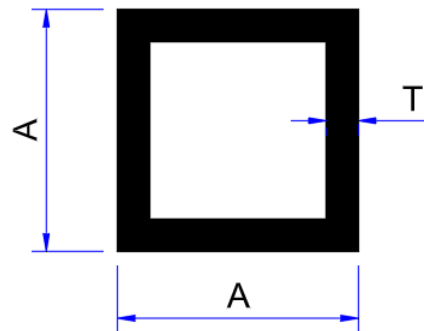

Sr. No.	Section No.	A	T	Kg/Mtr.	Kg/12 Ft
1	08018	25.00	0.95	0.247	0.90
2	08017	38.00	1.05	0.419	1.53
3	08001	38.00	1.25	0.496	1.81
4	08014	38.00	2.10	0.814	2.98
5	08019	38.10	0.89	0.358	1.31
6	08020	38.10	2.11	0.820	3.00
7	08015	50.00	1.60	0.836	3.06
8	08016	50.00	2.10	1.086	3.97
9	08013	50.00	3.00	1.523	5.57
10	08021	50.80	1.02	0.548	2.00

## RECTANGULAR TUBES

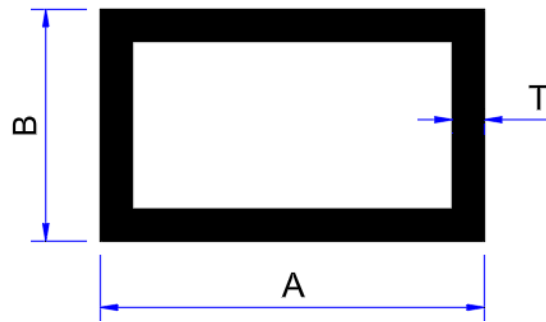

Sr. No.	Section No.	A	B	T	Kg/Mtr.	Kg/12 Ft
1	09026	36.00	24.00	0.80	0.252	0.92
2	09020	38.00	25.00	0.80	0.265	0.97
3	09016	38.10	25.40	0.70	0.235	0.86
4	09022	48.00	24.00	0.70	0.267	0.98
5	09018	50.00	25.00	0.58	0.231	0.84
6	09023	50.00	25.00	0.70	0.278	1.02
7	09015	50.00	25.00	0.80	0.317	1.16
8	09024	50.00	25.00	0.97	0.383	1.40
9	09014	50.00	25.00	1.40	0.546	2.00
10	09001	50.00	25.00	1.50	0.583	2.13
11	09025	50.00	25.00	1.55	0.602	2.20
12	09019	50.00	25.00	2.10	0.803	2.94
13	09028	50.80	25.40	2.71	1.036	3.79
14	09017	50.80	38.10	1.20	0.561	2.05
15	09021	63.00	38.00	1.00	0.535	1.96
16	09027	63.50	38.00	0.91	0.490	1.79
17	09029	75.00	25.00	0.88	0.467	1.71
18	09030	75.00	25.00	2.00	1.037	3.79
19	09031	82.50	38.10	1.20	0.766	2.80
20	09032	96.00	24.00	0.86	0.549	2.01
21	09033	100.00	44.50	1.43	1.094	4.00
22	09013	100.00	50.00	2.50	1.958	7.16
23	09035	150.00	25.00	1.60	1.484	5.43
24	09034	150.00	50.00	2.00	2.117	7.74

## ROUND TUBES

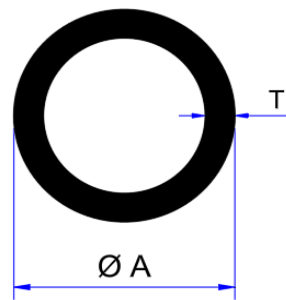

Sr. No.	Section No.	$\phi$ A	T	Kg/Mtr.
1	11048	8.00	2.00	0.102
2	11027	22.00	4.10	0.622
3	11023	22.50	6.15	0.853
4	11004	25.00	1.22	0.246
5	11005	25.00	1.50	0.299
6	11028	25.00	3.00	0.560
7	11006	25.40	0.83	0.173
8	11029	28.00	4.00	0.814
9	11001	28.60	2.00	0.451
10	11007	38.00	1.20	0.375
11	11008	38.00	2.00	0.611
12	11049	38.10	3.25	0.961
13	11014	49.50	8.75	3.024
14	11019	49.50	8.25	2.887
15	11009	50.00	1.50	0.617
16	11010	50.00	2.00	0.814
17	11030	50.00	5.00	1.909
18	11020	51.50	9.25	3.315
19	11035	54.00	8.50	3.281
20	11021	55.20	8.95	3.511
21	11015	56.00	6.25	2.637
22	11022	58.20	7.40	3.189
23	11011	65.00	2.00	1.069

Sr. No.	Section No.	$\phi$ A	T	Kg/Mtr.
24	11012	75.00	3.00	1.832
25	11031	75.00	5.00	2.969
26	11032	75.00	6.00	3.512
27	11013	76.00	2.50	1.559
28	11025	80.00	4.00	2.579
29	11036	80.00	10.00	5.938
30	11037	80.00	15.00	8.270
31	11038	80.00	20.00	10.179
32	11033	85.00	3.00	2.087
33	11039	100.00	15.00	10.815
34	11040	100.00	16.00	11.400
35	11034	110.00	5.00	4.453
36	11041	110.00	15.00	12.087
37	11052	112.00	21.00	16.210
38	11026	120.00	5.00	4.877
39	11024	120.00	6.27	6.049
40	11042	120.00	13.00	11.799
41	11043	120.00	15.00	13.360
42	11044	120.00	17.50	15.215
43	11045	121.00	30.50	23.413
44	11018	123.00	16.50	14.906
45	11017	126.50	24.25	21.032
46	11046	130.00	25.00	22.266

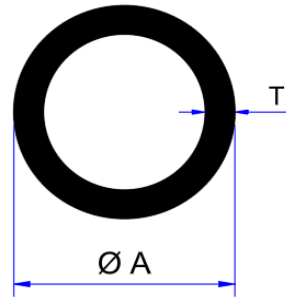

Sr. No.	Section No.	$\varnothing A$	T	Kg/Mtr.
47	11047	135.00	32.50	28.257
48	11050	165.00	16.00	20.222
49	11016	180.00	12.50	17.760
50	11051	196.00	10.50	16.521

## IPS TUBES

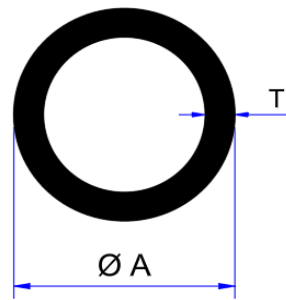

### SCHEDULE- 40

Sr. No.	Section No.	Size	A	T	Kg/Mtr.
1	24001	1"	33.40	3.42	0.870
2	24002	1 ¼"	42.16	3.56	1.164
3	24003	1 ½"	48.26	3.68	1.392
4	24004	2"	60.32	3.91	1.871
5	24005	2 ½"	73.03	5.16	2.971
6	24006	3"	88.90	5.49	3.884
7	24007	3 ½"	101.60	5.74	4.667
8	24008	4"	114.30	6.35	5.814
9	24009	4 ½"	127.00	6.27	6.421
10	24010	5"	141.30	6.55	7.487

### SCHEDULE- 80

Sr. No.	Section No.	Size	A MM	T MM	Kg/Mtr.
1	24011	1 ½"	48.26	5.08	1.861
2	24012	2"	60.33	5.54	2.575
3	24013	2 ½"	73.03	7.01	3.926
4	24014	3"	88.90	7.62	5.254
5	24015	3 ½"	101.60	8.08	6.410
6	24016	4"	114.20	8.51	7.629
7	24017	4 ½"	127.00	9.02	9.024
8	24018	4 ½"	120.00	12.00	10.993
9	24019	5"	141.30	9.53	10.652
10	24020	6"	160.00	10.00	12.723
11	24021	6"	170.00	8.00	10.993
12	24022	6"	168.00	10.97	14.612

## T- SECTIONS

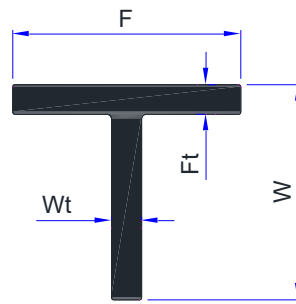

Sr. No.	Section No.	F	Ft	W	Wt	Kg/Mtr.
1	25001	110.00	6.00	206.00	6.00	5.023
2	25002	70.00	8.00	108.00	4.00	2.599
3	25003	110.00	8.00	158.00	8.00	5.617
4	25004	70.00	8.00	98.00	4.00	2.491
5	25005	200.00	6.00	110.00	6.00	4.926
6	25006	100.00	4.00	70.00	8.00	2.513
7	25007	150.00	8.00	110.00	8.00	5.444
8	25008	90.00	4.00	70.00	8.00	2.405

## H – SECTIONS

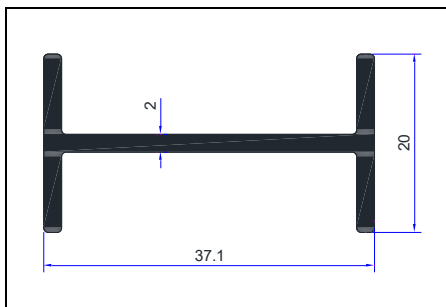

SECTION NO.	THK.	WEIGHT KG/M
12002	2.0	0.394

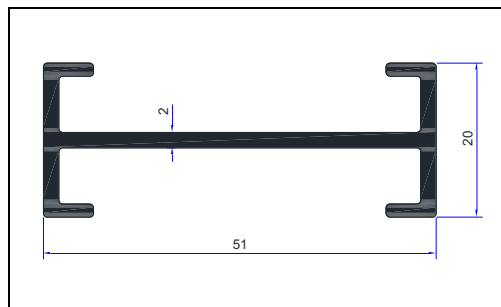

SECTION NO.	THK.	WEIGHT KG/M
12003	2.0	0.552

## FURNITURES

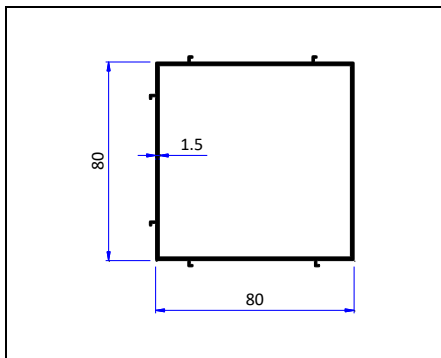

SECTION NO.	THK.	WEIGHT KG/M
14052	1.5	1.330

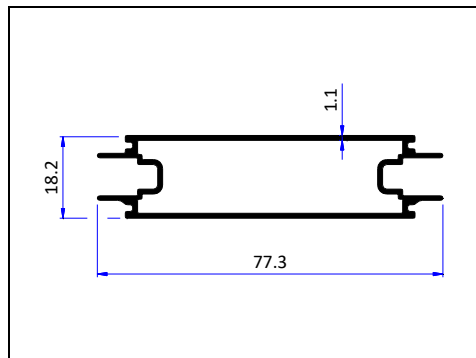

SECTION NO.	THK.	WEIGHT KG/M
14053	1.1	0.648

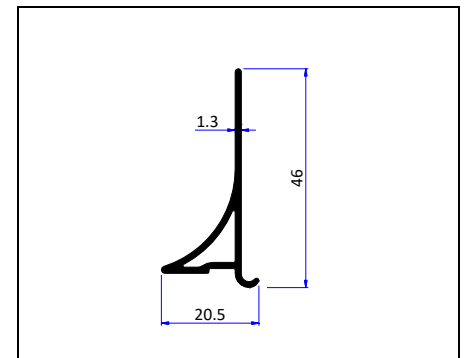

SECTION NO.	THK.	WEIGHT KG/M
14054	1.3	0.301

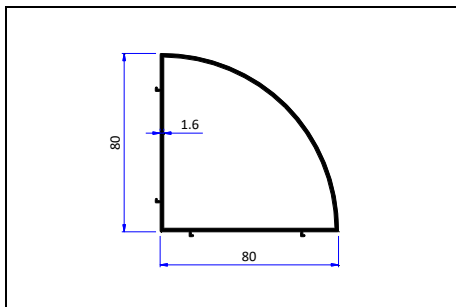

SECTION NO.	THK.	WEIGHT KG/M
14055	1.6	1.244

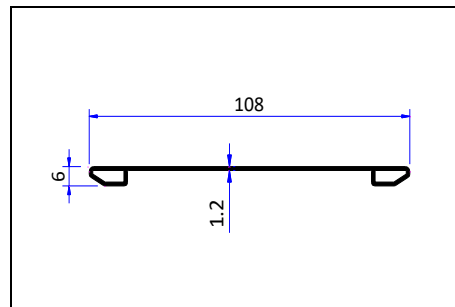

SECTION NO.	THK.	WEIGHT KG/M
14078	1.2	0.464

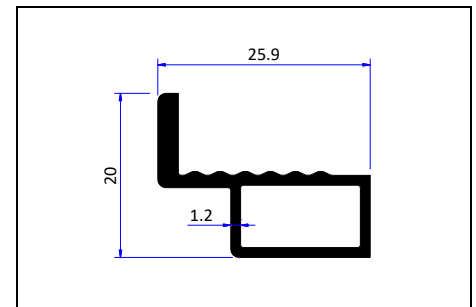

SECTION NO.	THK.	WEIGHT KG/M
14079	1.2	0.274

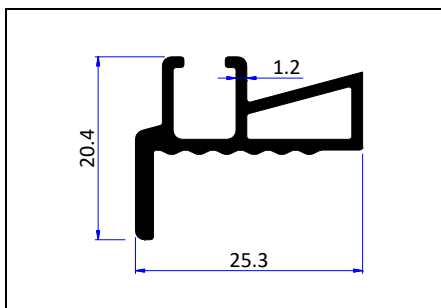

SECTION NO.	THK.	WEIGHT KG/M
14080	1.2	0.288

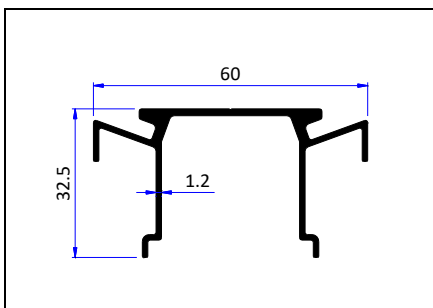

SECTION NO.	THK.	WEIGHT KG/M
15009	1.2	0.594

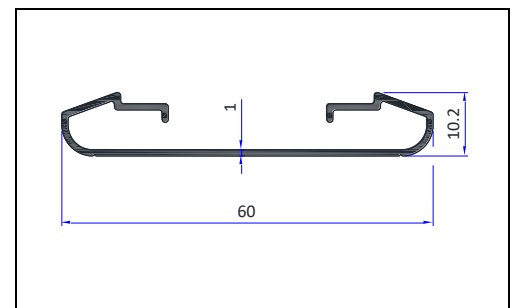

SECTION NO.	THK.	WEIGHT KG/M
15010	1.0	0.295

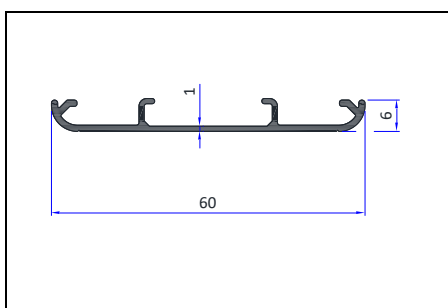

SECTION NO.	THK.	WEIGHT KG/M
15011	1.0	0.264

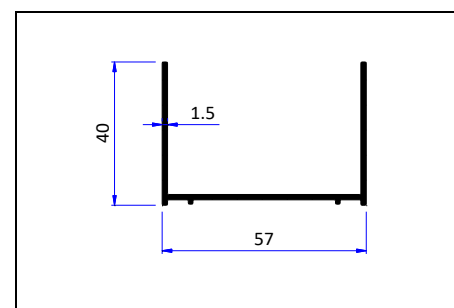

SECTION NO.	THK.	WEIGHT KG/M
15024	1.5	0.551

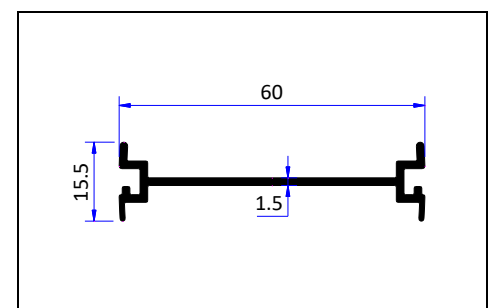

SECTION NO.	THK.	WEIGHT KG/M
15025	1.5	0.391

# FURNITURE

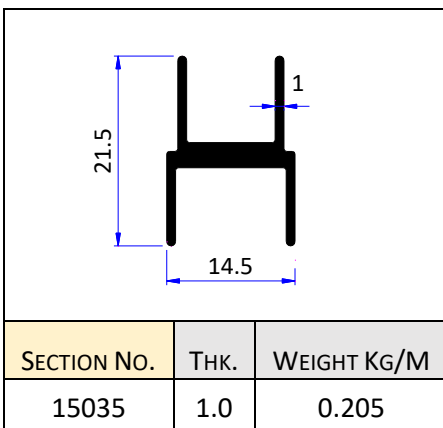
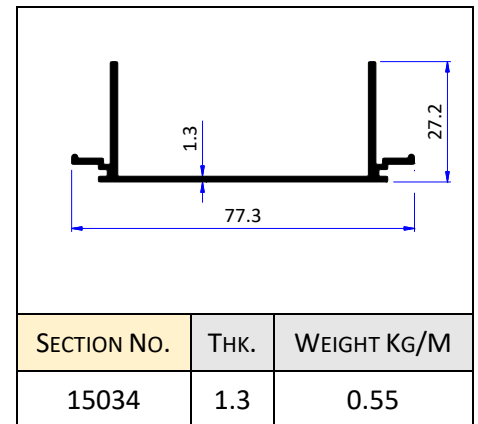
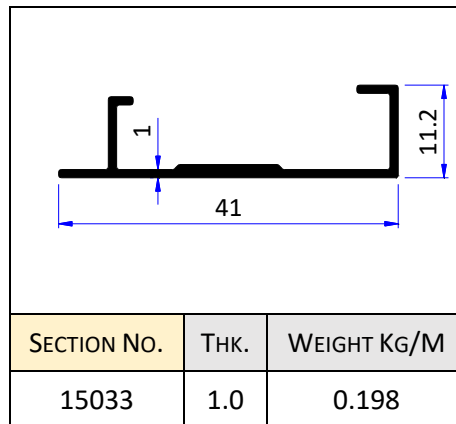
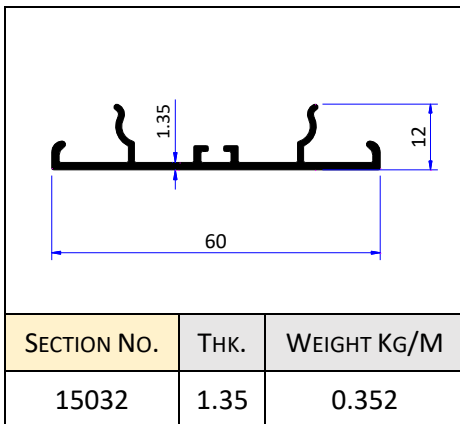
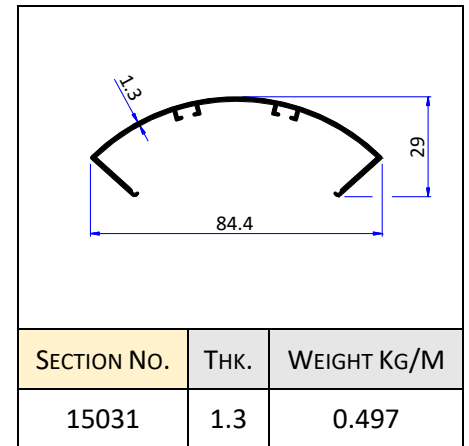
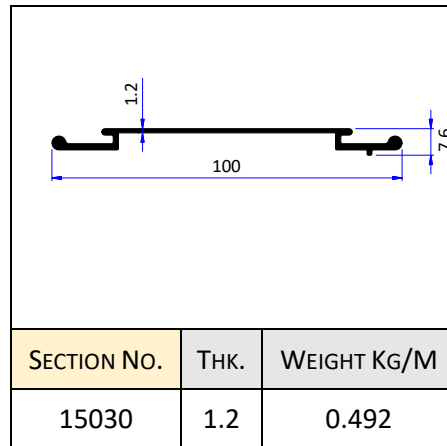
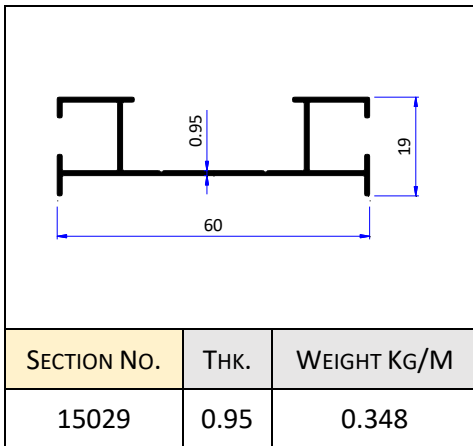
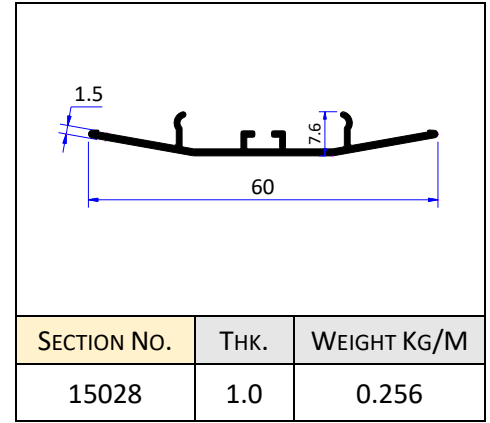
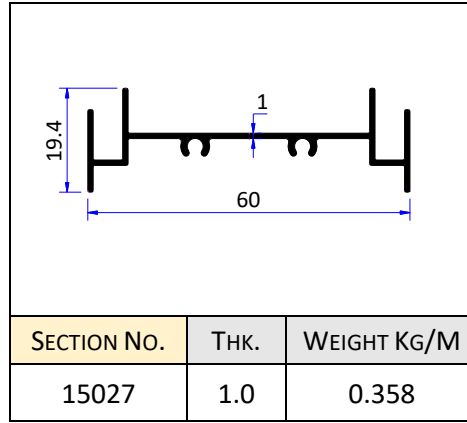
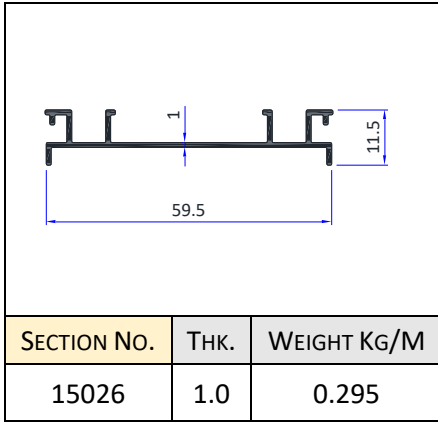

## MINIMAL GLASS ADAPTER

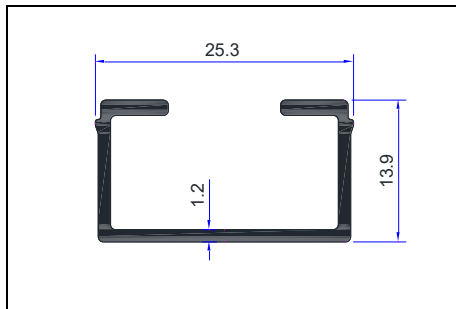

SECTION NO.	THK.	WEIGHT KG/M
10016	1.2	0.207

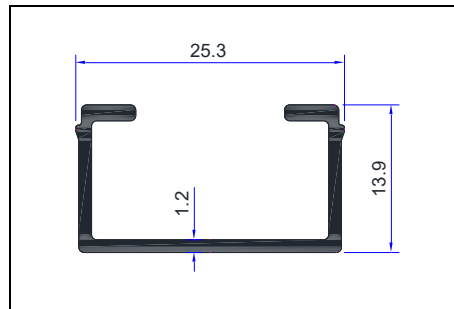

SECTION NO.	THK.	WEIGHT KG/M
10017	1.2	0.195

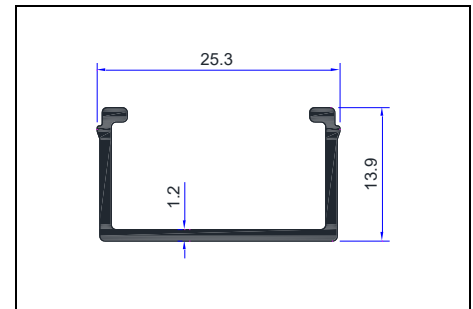

SECTION NO.	THK.	WEIGHT KG/M
10018	1.2	0.174

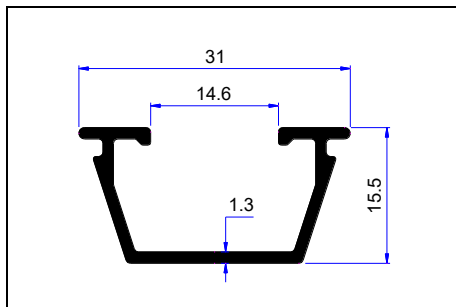

SECTION NO.	THK.	WEIGHT KG/M
15068	1.3	0.236

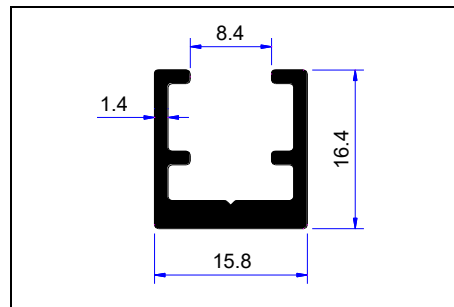

SECTION NO.	THK.	WEIGHT KG/M
15069	1.4	0.259

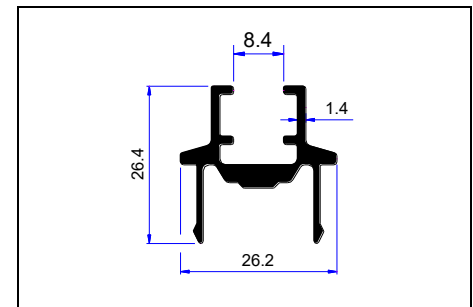

SECTION NO.	THK.	WEIGHT KG/M
15070	1.4	0.403

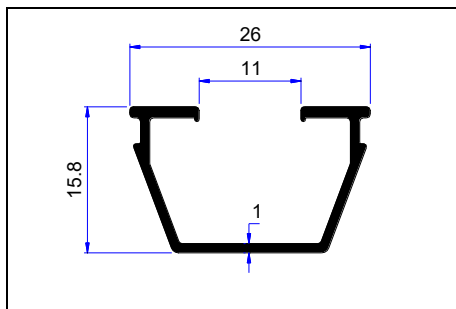

SECTION NO.	THK.	WEIGHT KG/M
15093	1.0	0.177

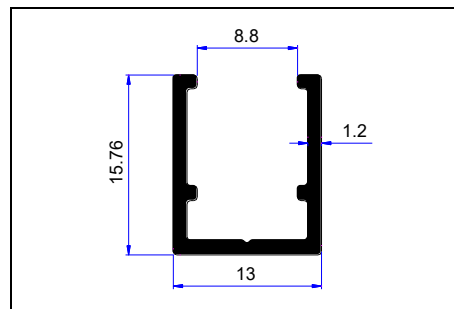

SECTION NO.	THK.	WEIGHT KG/M
15108	1.2	0.151

## DOORS & PARTITION

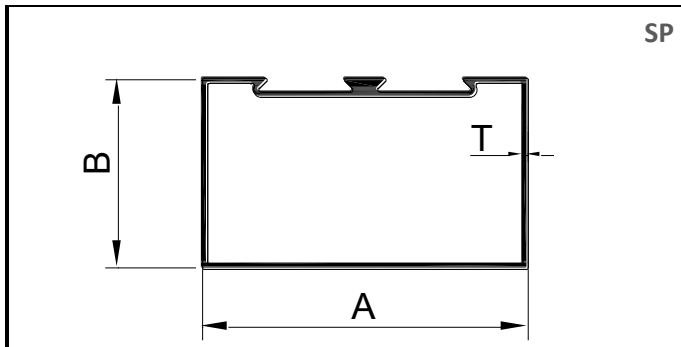

Section No.	A	B	T	Weight Kg/M
14002	63.00	37.00	1.00	0.599
14001	63.00	37.00	1.20	0.705
14003	63.00	37.00	1.50	0.862
14043	63.00	38.00	0.78	0.488
14038	101.60	44.45	1.20	1.004

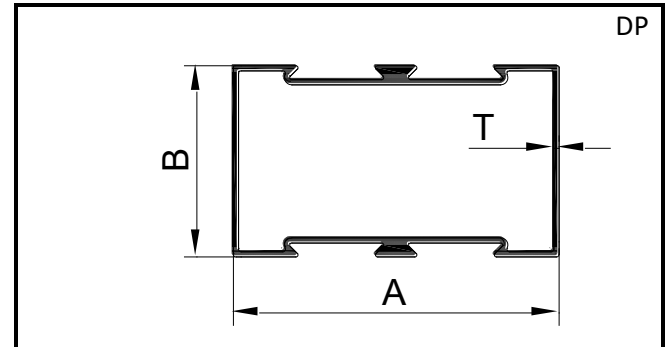

Section No.	A	B	T	Weight Kg/M
14010	63.00	37.00	1.00	0.669
14009	63.00	37.00	1.20	0.778
14044	63.00	38.00	0.65	0.490
14039	101.60	44.45	1.10	0.998

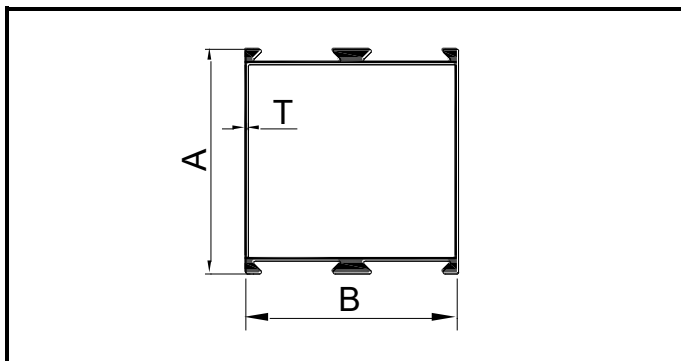

Section No.	A	B	T	Weight Kg/M
14032	47.00	44.50	0.54	0.413
14006	47.00	44.50	1.00	0.619
14007	47.00	44.50	1.20	0.707
14008	47.00	44.50	1.50	0.838

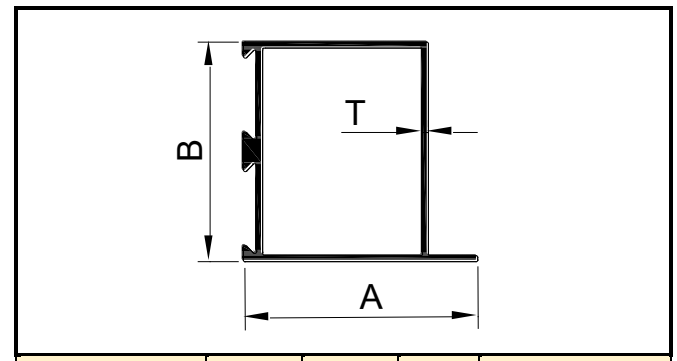

Section No.	A	B	T	Weight Kg/M
14040	47.50	44.50	1.20	0.613

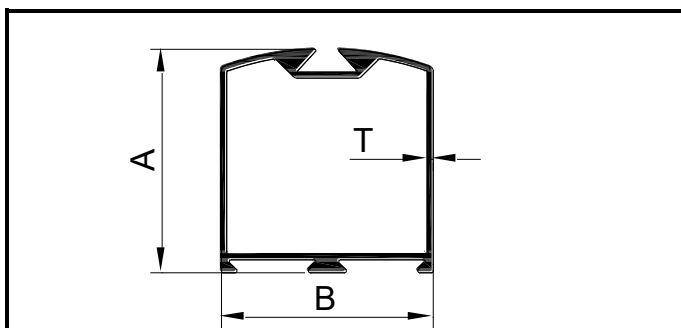

Section No.	A	B	T	Weight Kg/M
14011	47.00	44.50	1.10	0.695
14042	47.20	44.20	0.75	0.464
14051	85.00	44.45	1.28	1.027

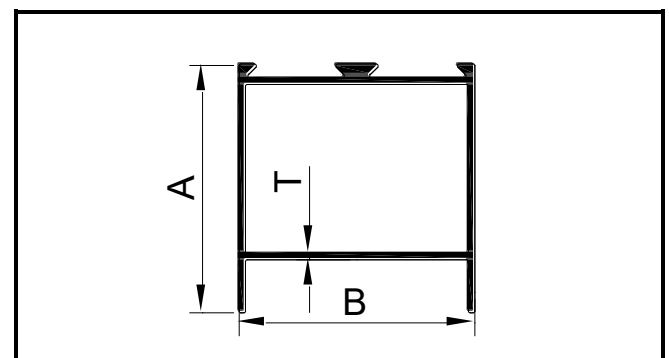

Section No.	A	B	T	Weight Kg/M
14004	47.00	44.50	1.20	0.642
14005	47.00	44.50	1.50	0.777
14045	47.20	44.20	0.75	0.441
14041	114.00	44.50	1.10	0.995

## SLIDING WINDOW

### 18 mm Series

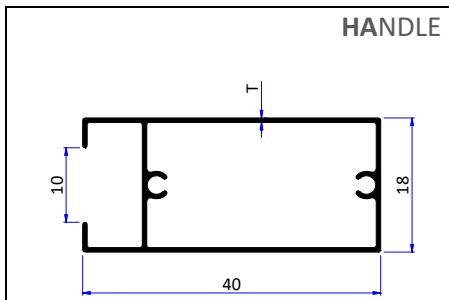

SECTION NO.	THK.	WEIGHT KG/M
14029	0.6	0.217
14012	1.1	0.385

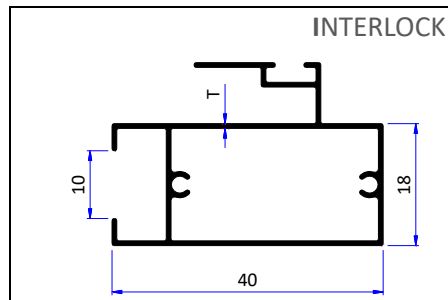

SECTION NO.	THK.	WEIGHT KG/M
14030	0.7	0.314
14014	1.1	0.486

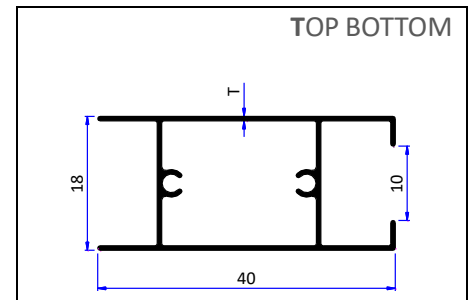

SECTION NO.	THK.	WEIGHT KG/M
14031	0.6	0.217
14013	1.1	0.388

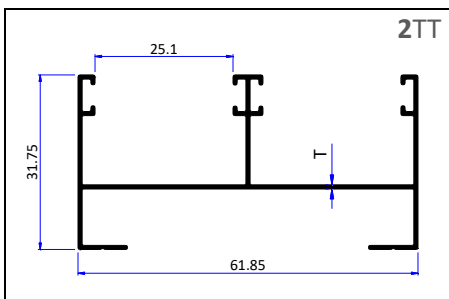

SECTION NO.	THK.	WEIGHT KG/M
15017	0.75	0.380
15003	1.1	0.565

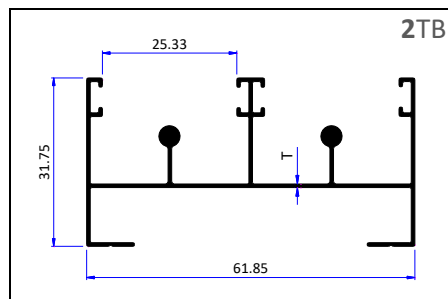

SECTION NO.	THK.	WEIGHT KG/M
15016	0.68	0.438
15004	1.1	0.676

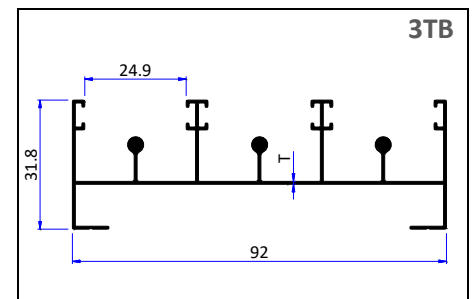

SECTION NO.	THK.	WEIGHT KG/M
15019	0.72	0.632
15022	1.1	0.919
15005	1.5	1.324

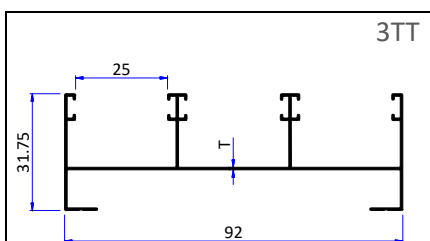

SECTION NO.	THK.	WEIGHT KG/M
15018	0.7	0.474
15006	1.5	1.045

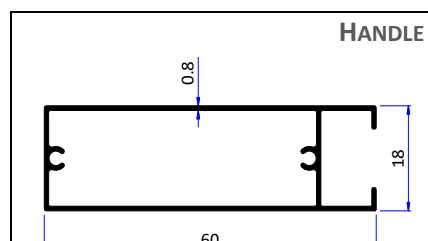

SECTION NO.	THK.	WEIGHT KG/M
14033	0.8	0.372

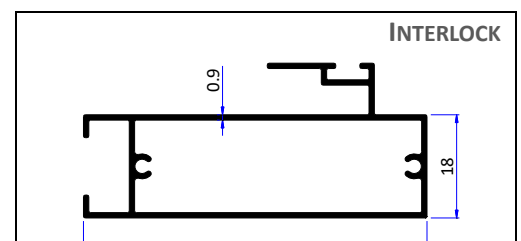

SECTION NO.	THK.	WEIGHT KG/M
14034	0.9	0.513

# SLIDING WINDOW

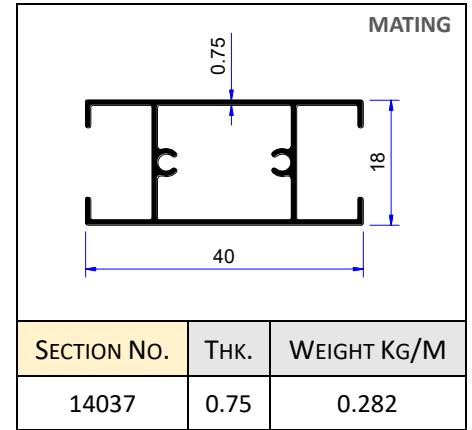
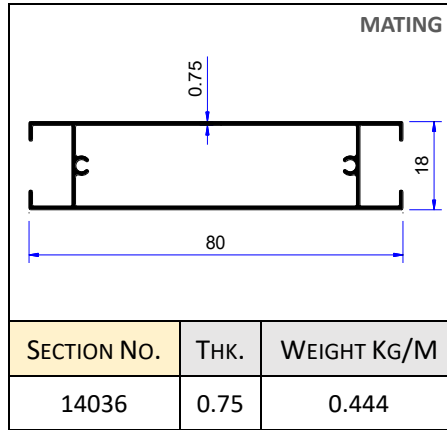
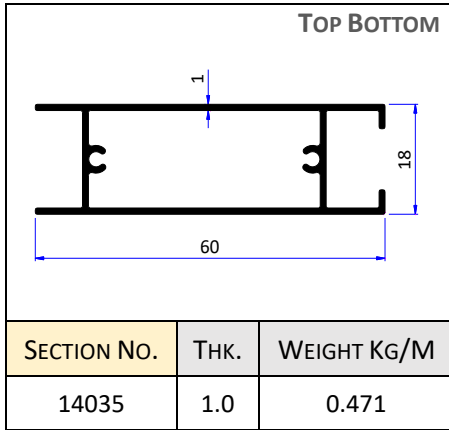

# SLIDING WINDOW

## 25 mm Series.

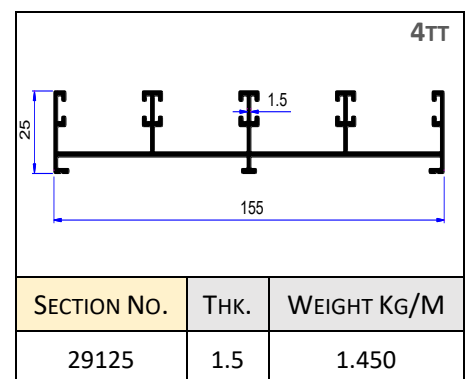
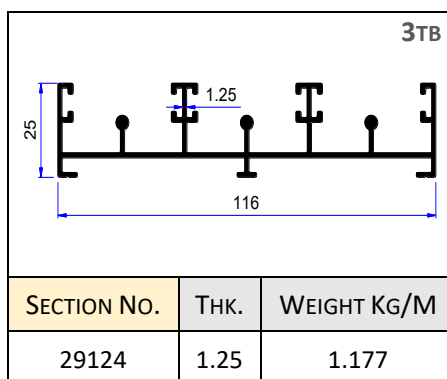
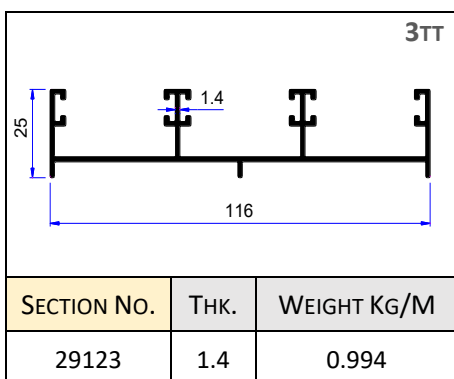
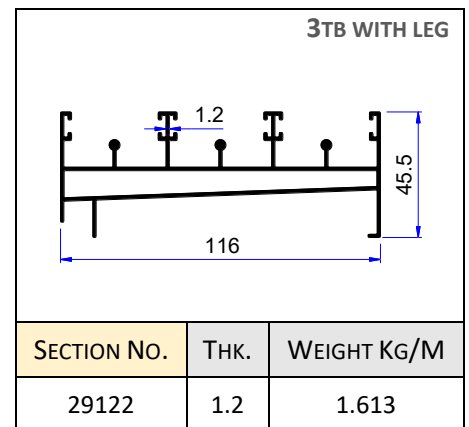
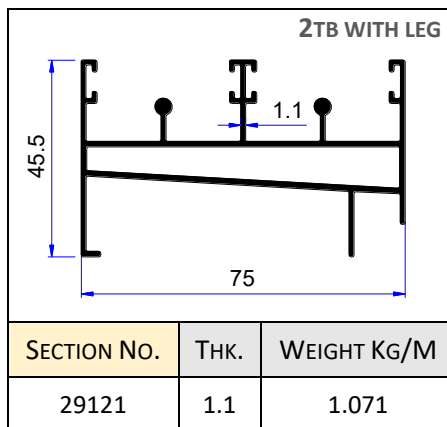
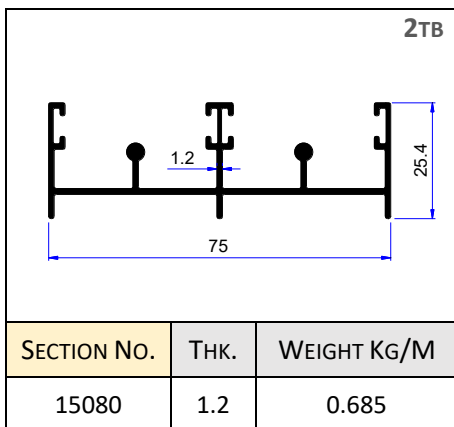
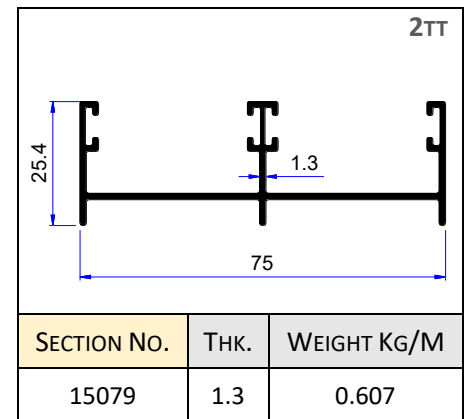
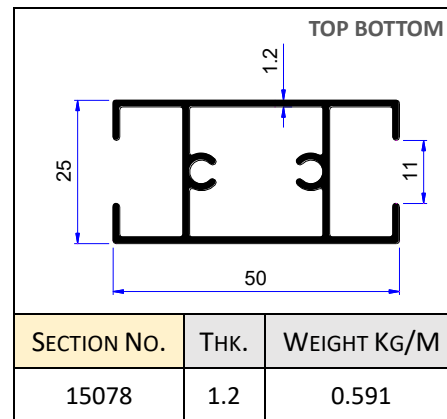
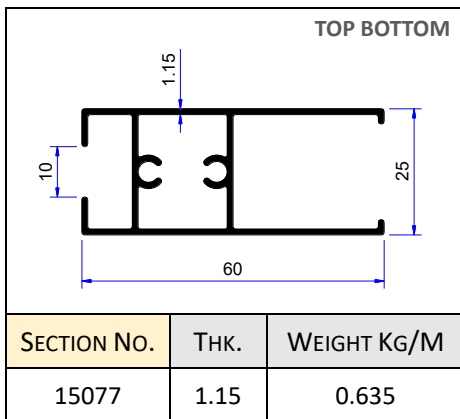
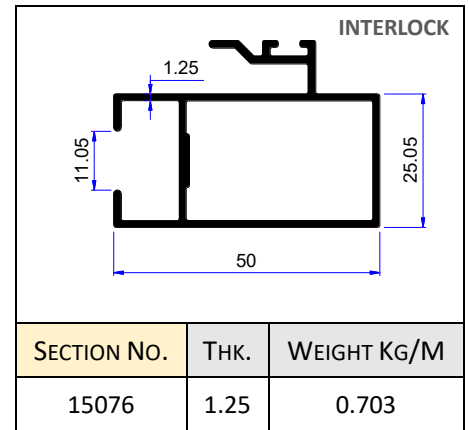
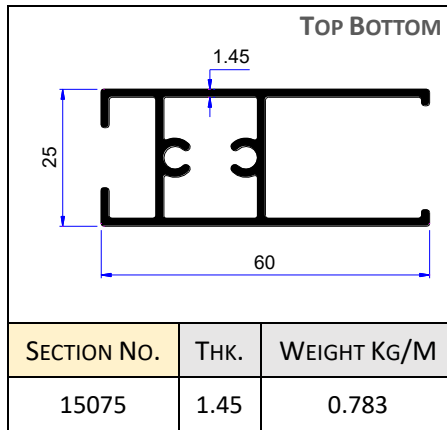
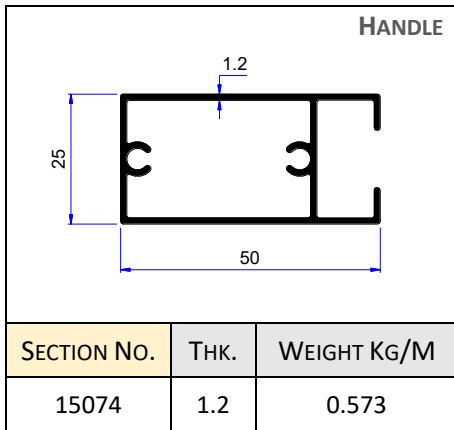

# SLIDING WINDOW

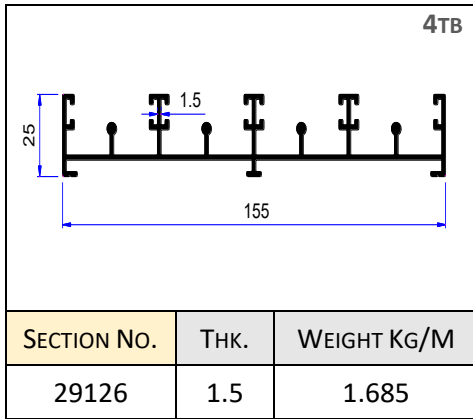

## 20 X 54 Sliding

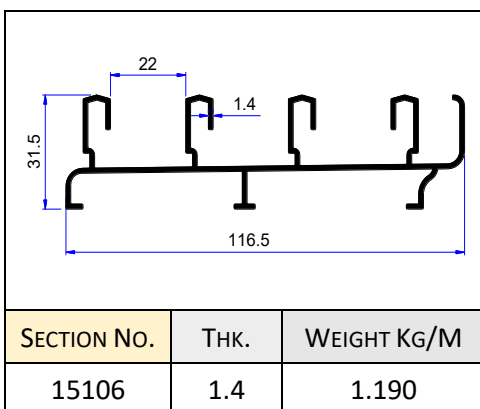
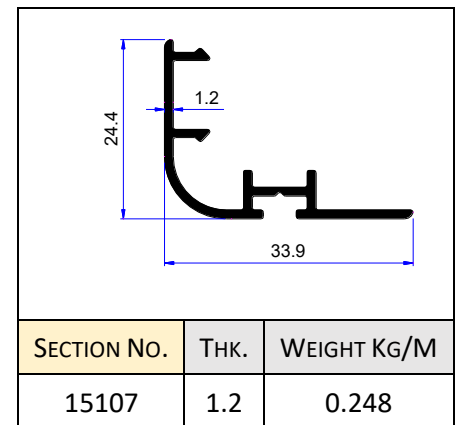
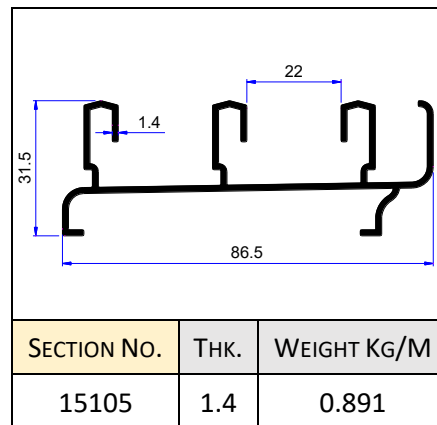
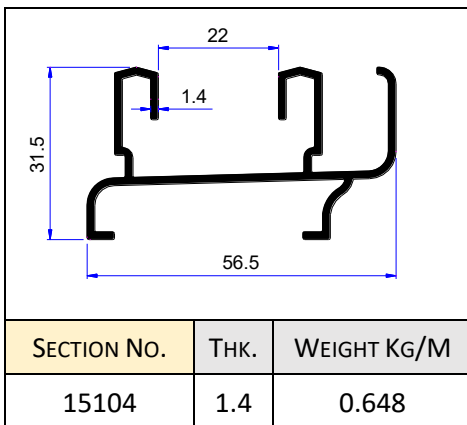
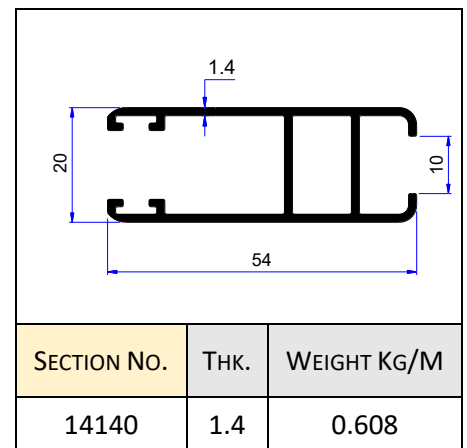
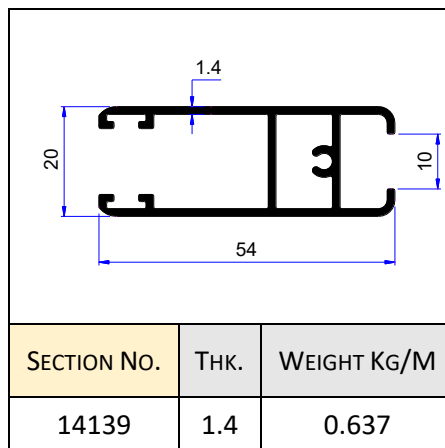
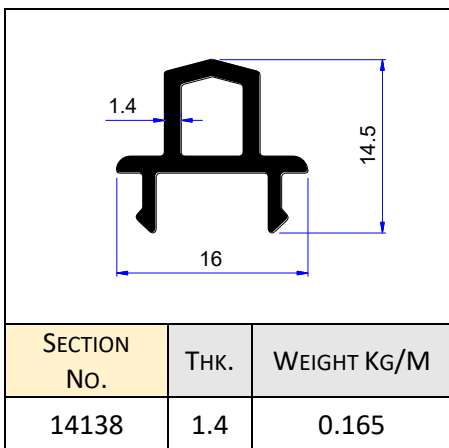

All dimensions in mm.

## SLIDING WINDOW 27 X 65 Domal Series.

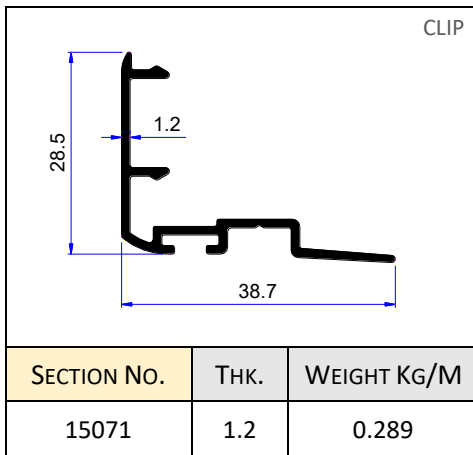
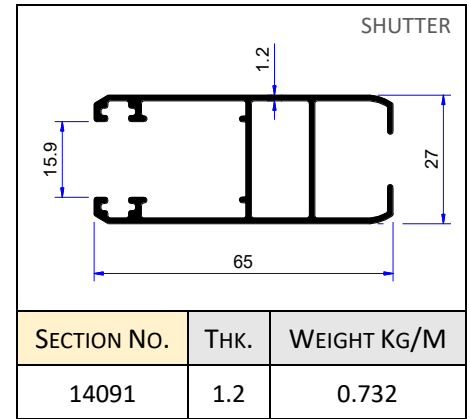
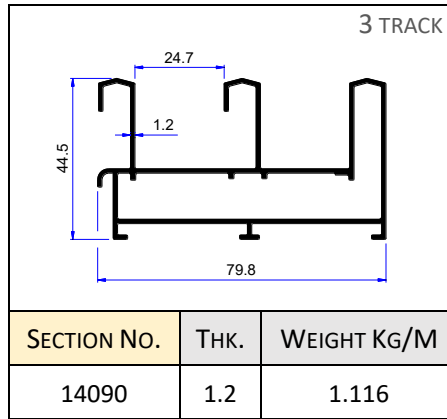
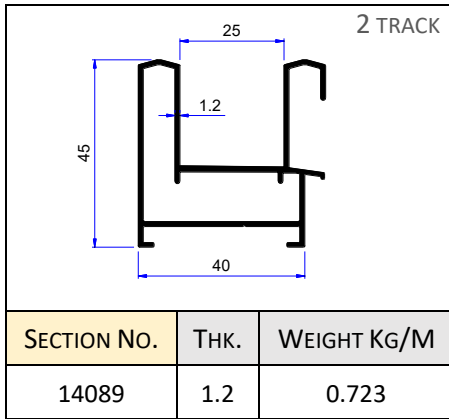

## 27 X 65 Lite Series.

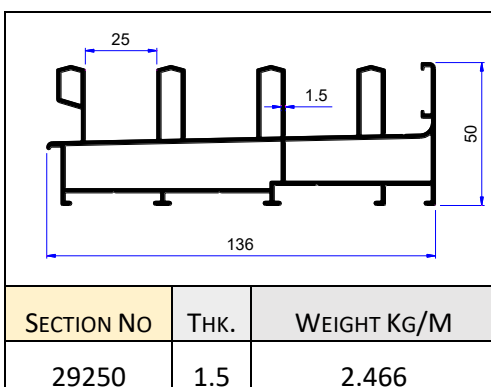
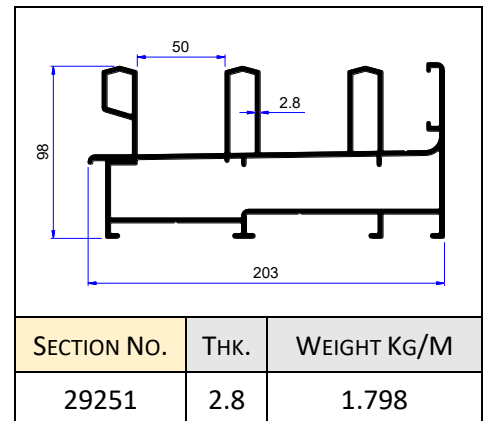
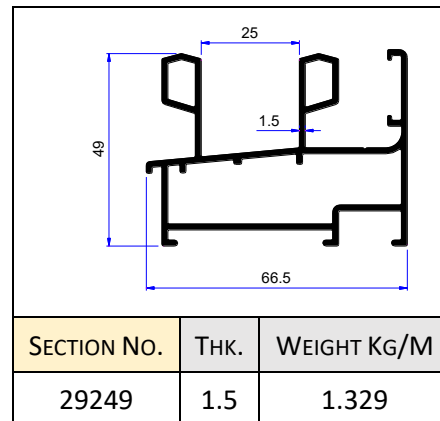
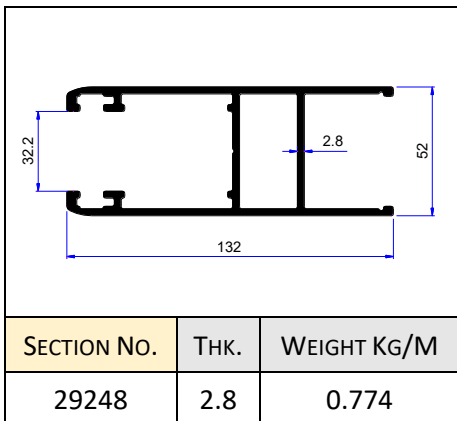

## SLIDING WINDOW 29 mm Series

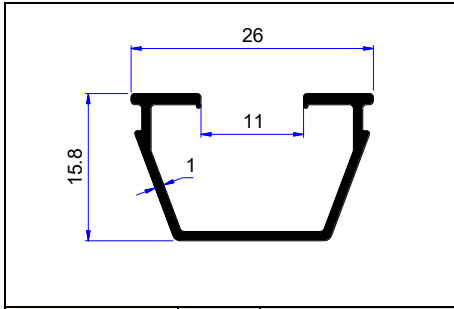

SECTION NO.	THK.	WEIGHT KG/M
15093	1.0	0.177

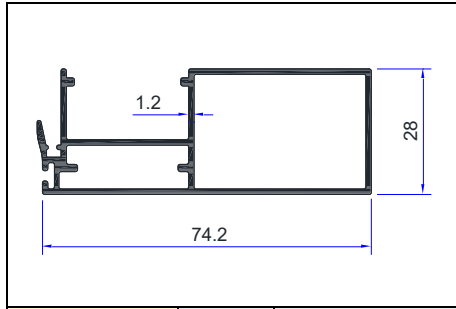

SECTION NO.	THK.	WEIGHT KG/M
14112	1.2	0.817

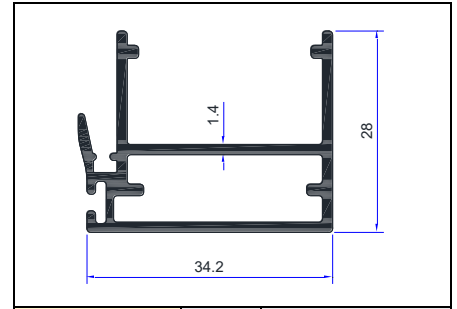

SECTION NO.	THK.	WEIGHT KG/M
14113	1.4	0.527

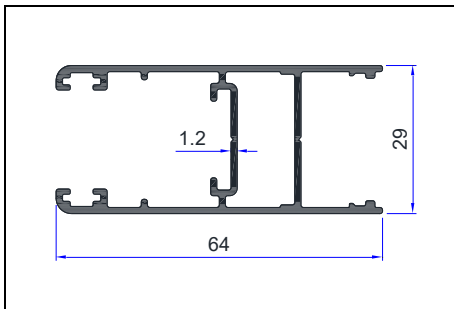

SECTION NO.	THK.	WEIGHT KG/M
14114	1.2	0.740

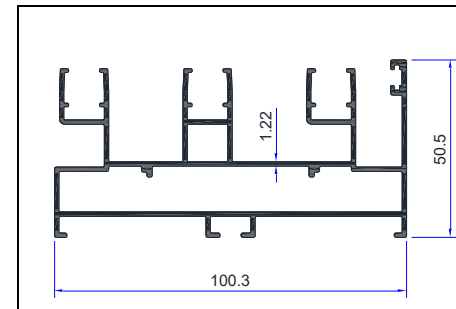

SECTION NO.	THK.	WEIGHT KG/M
14115	1.22	1.644

## 37 mm Opulence.

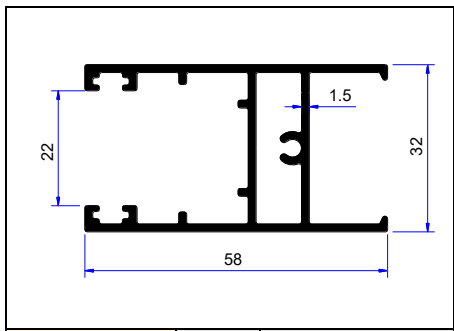

SECTION NO.	THK.	WEIGHT KG/M
14081	1.50	0.870

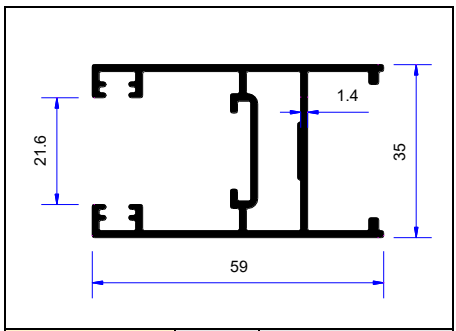

SECTION NO.	THK.	WEIGHT KG/M
14082	1.40	0.892

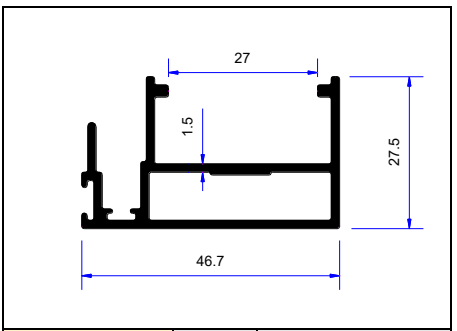

SECTION NO.	THK.	WEIGHT KG/M
14083	1.50	0.680

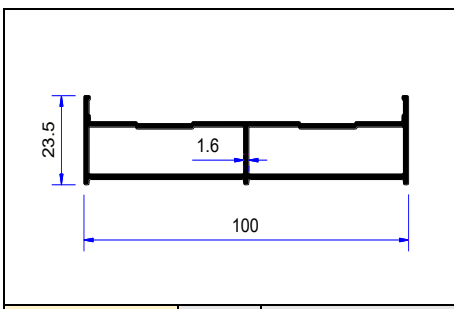

SECTION NO.	THK.	WEIGHT KG/M
14081	1.6	0.870

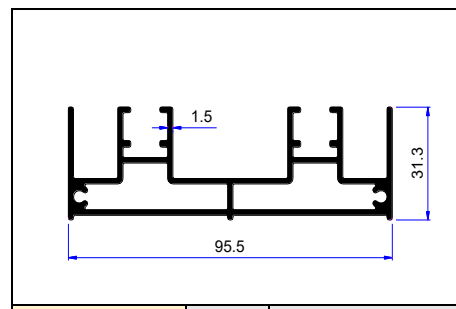

SECTION NO.	THK.	WEIGHT KG/M
14082	1.5	0.892

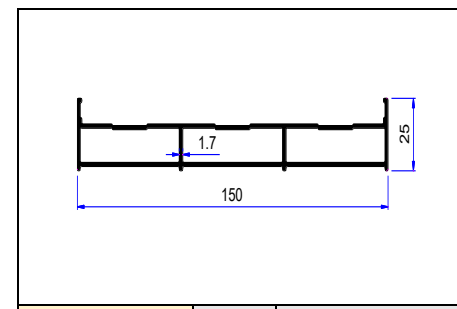

SECTION NO.	THK.	WEIGHT KG/M
14083	1.7	0.680

# SLIDING WINDOW

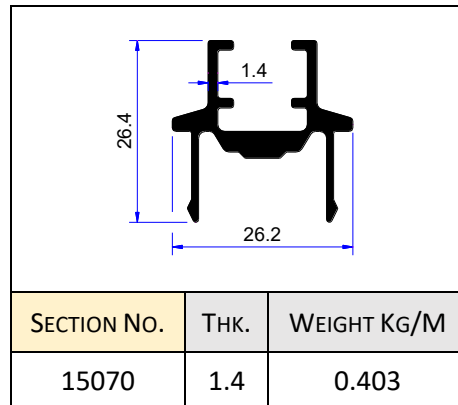
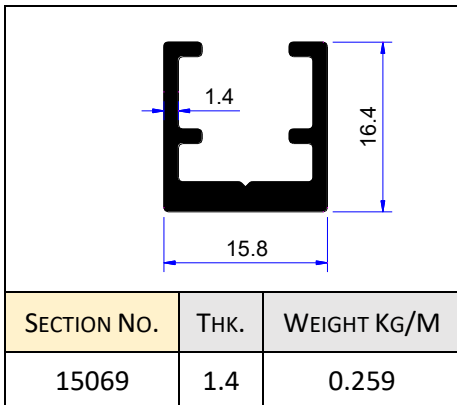
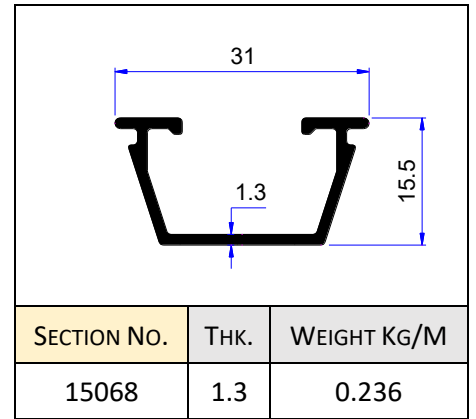
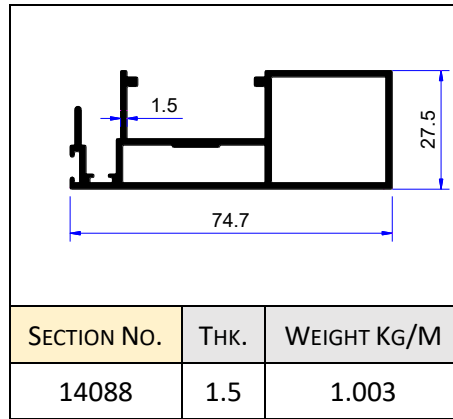
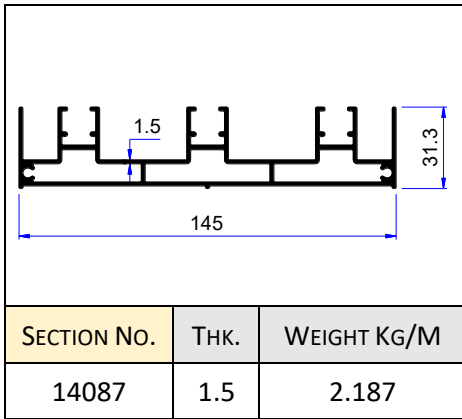

## CASEMENT SERIES

### 45 mm Unitised Casement.

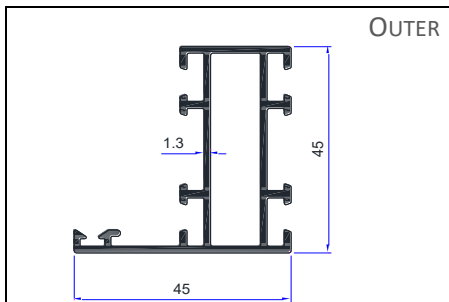

SECTION NO.	THK.	WEIGHT KG/M
14108	1.3	0.765

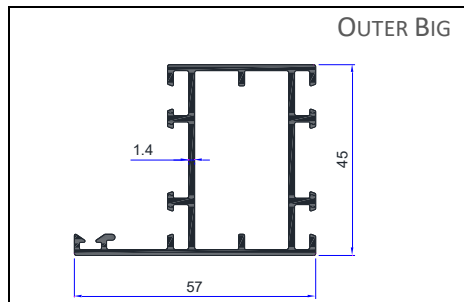

SECTION NO.	THK.	WEIGHT KG/M
14109	1.4	0.906

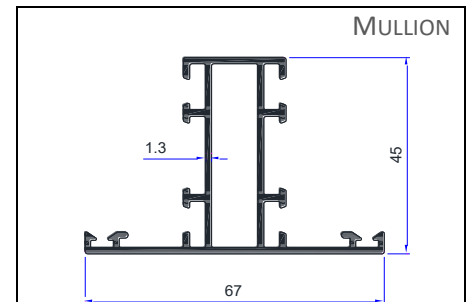

SECTION NO.	THK.	WEIGHT KG/M
14110	1.3	0.884

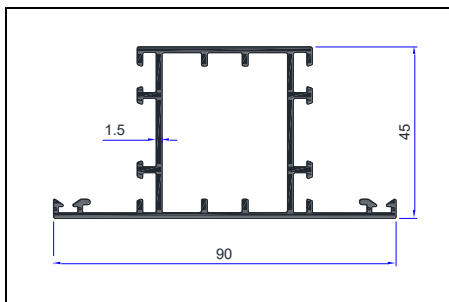

SECTION NO.	THK.	SECTION NO.
14111	1.5	1.179

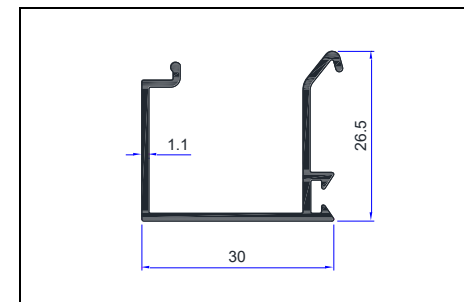

SECTION NO.	THK.	WEIGHT KG/M
15094	1.1	0.287

## CASEMENT SERIES

### 45 mm Casement.

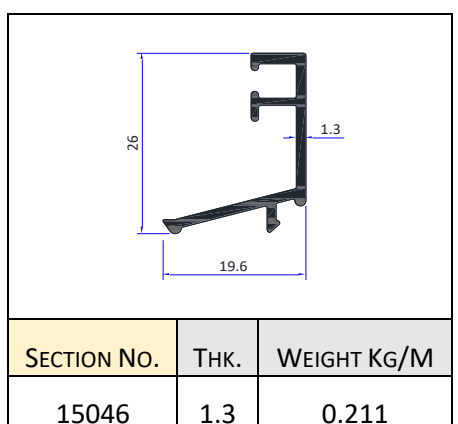
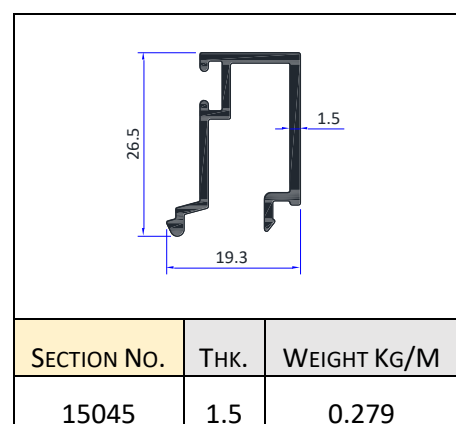
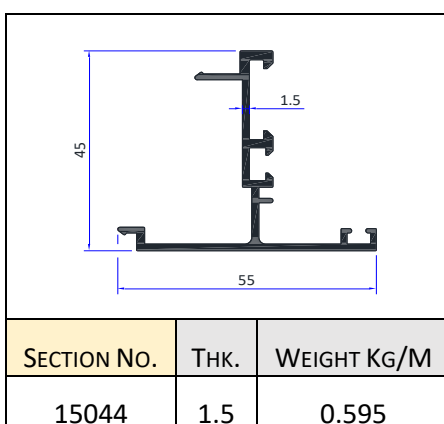
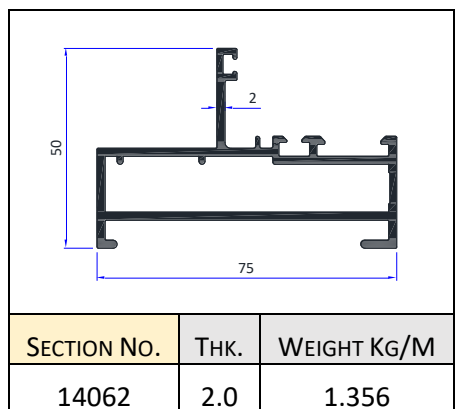
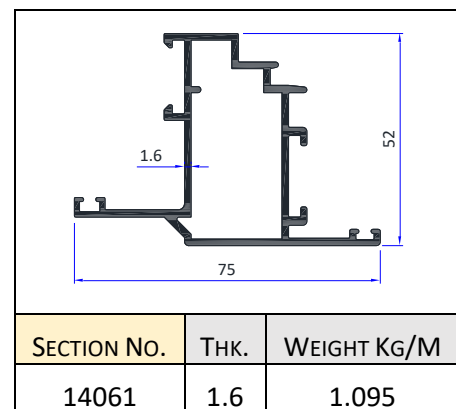
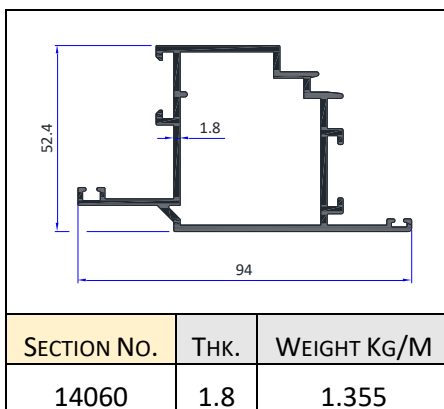
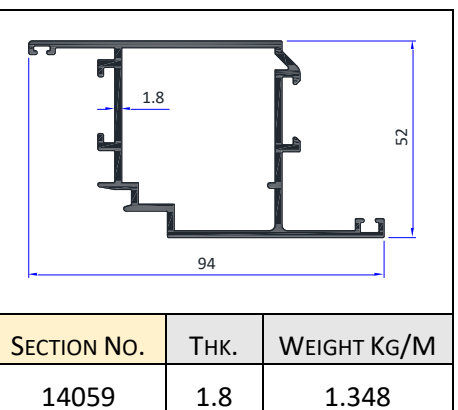
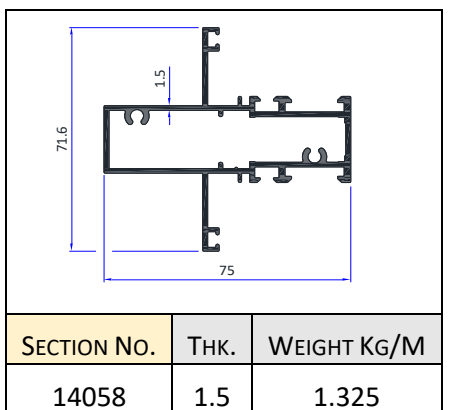
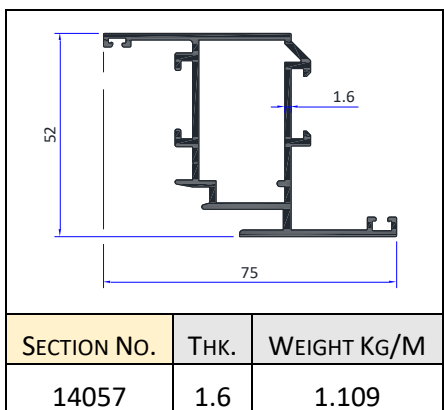
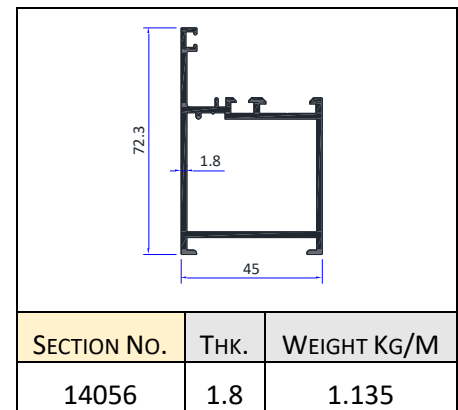
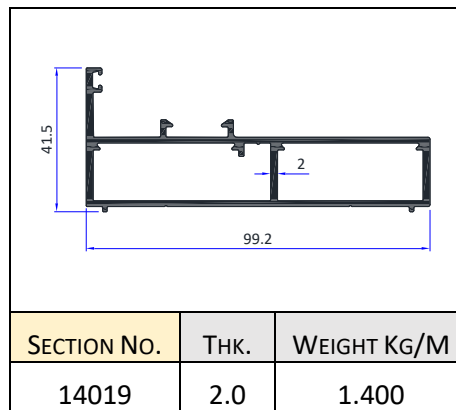
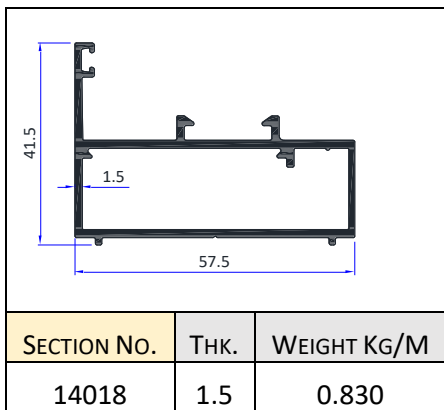

# CASEMENT SERIES

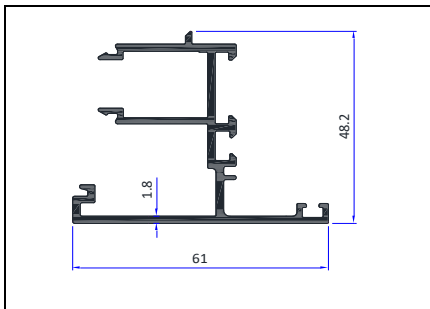

SECTION NO.	THK.	WEIGHT KG/M
15047	1.8	0.954

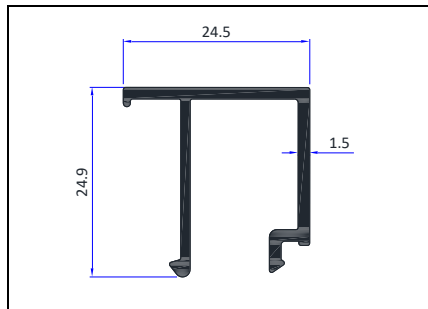

SECTION NO.	THK.	WEIGHT KG/M
15048	1.5	0.296

## 50 mm Series.

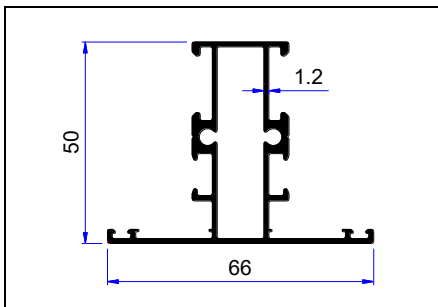

SECTION NO.	THK.	WEIGHT KG/M
29103	1.2	0.882

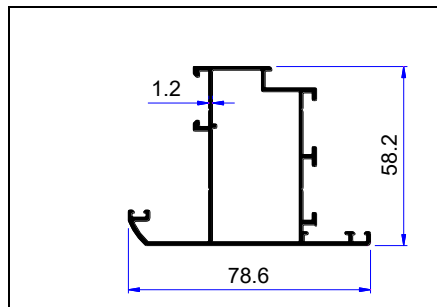

SECTION NO.	THK.	WEIGHT KG/M
29104	1.2	0.973

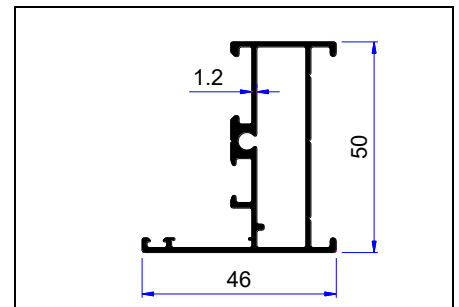

SECTION NO.	THK.	WEIGHT KG/M
29105	1.2	0.702

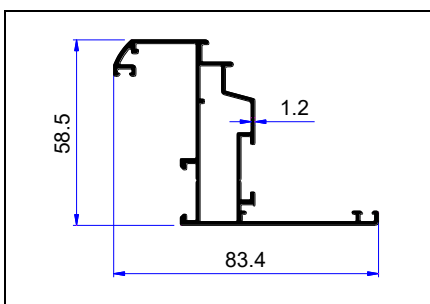

SECTION No.	THK.	WEIGHT KG/M
29106	1.2	0.919

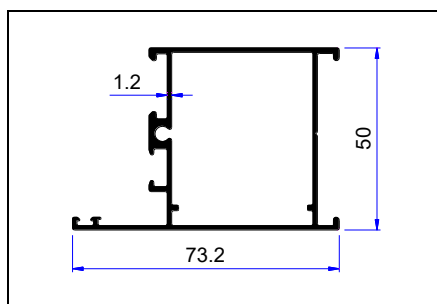

SECTION NO.	THK.	WEIGHT KG/M
29107	1.2	0.893

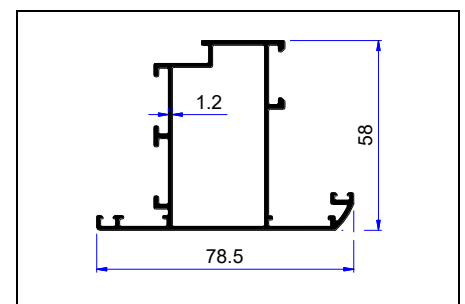

SECTION No.	THK.	WEIGHT KG/M
29108	1.2	0.997

# CASEMENT SERIES

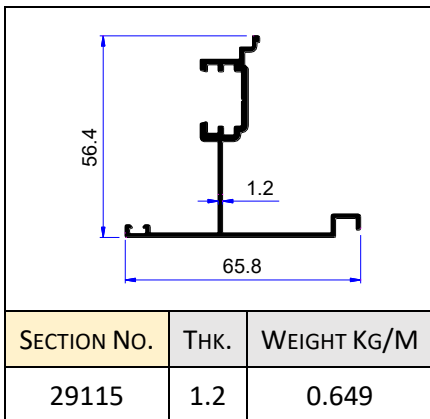
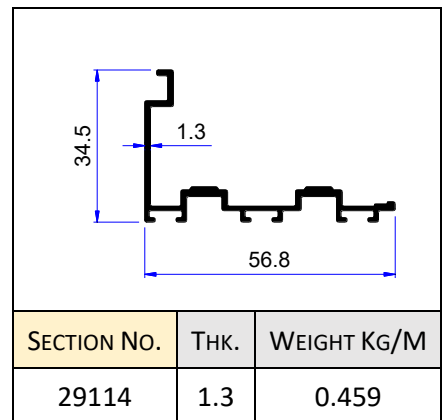
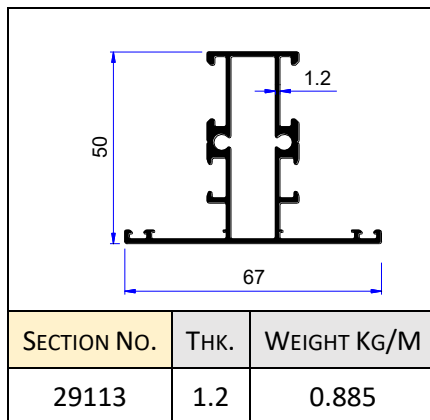
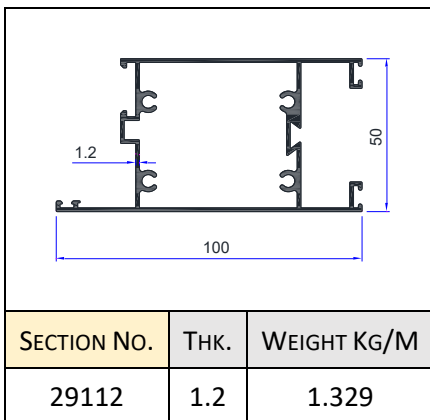
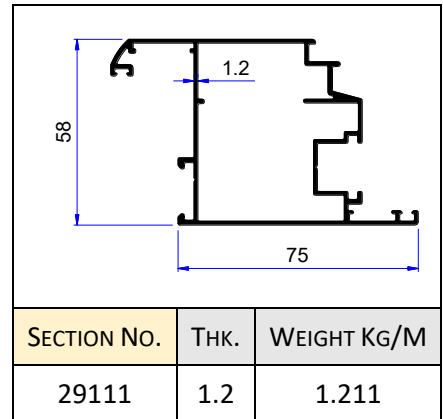
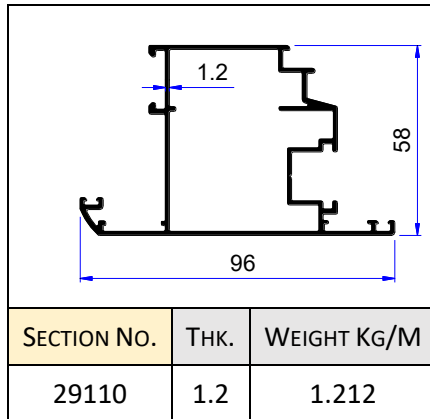
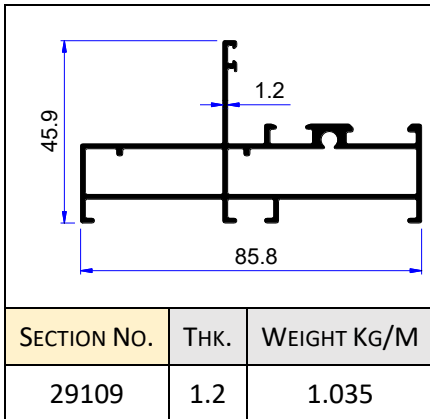

# CASEMENT SERIES

## Glazing clips



SECTION NO.	THK.	WEIGHT KG/M
29100	1.2	0.316

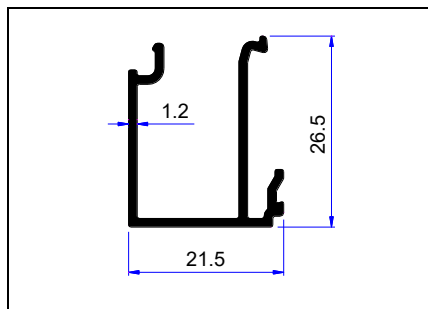

SECTION NO.	THK.	WEIGHT KG/M
29101	1.2	0.274

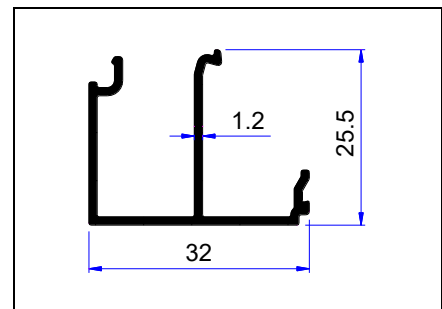

SECTION NO.	THK.	WEIGHT KG/M
29102	1.2	0.302

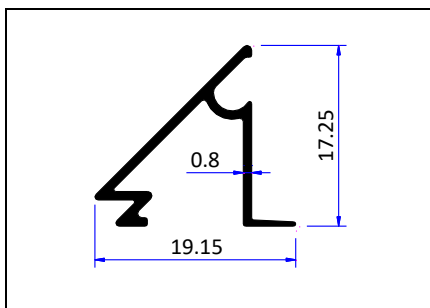

SECTION NO.	THK.	WEIGHT KG/M
15001	0.8	0.107

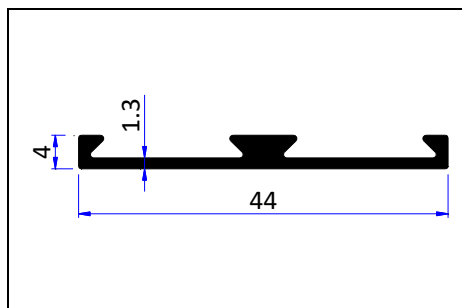

SECTION NO.	THK.	WEIGHT KG/M
15002	1.3	0.233

## TRANSPORT SECTION

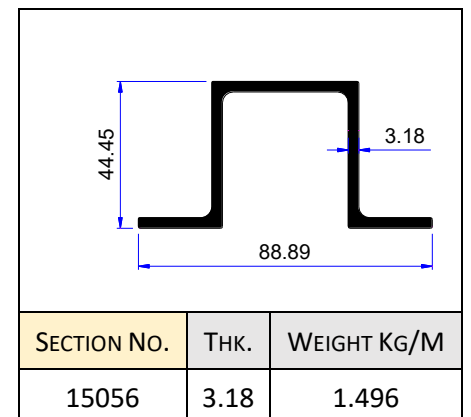
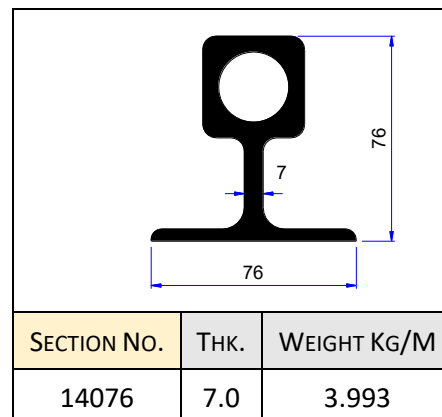
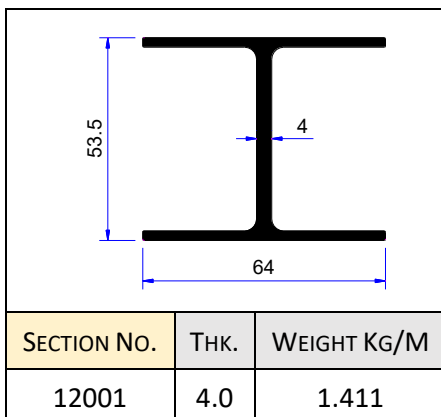
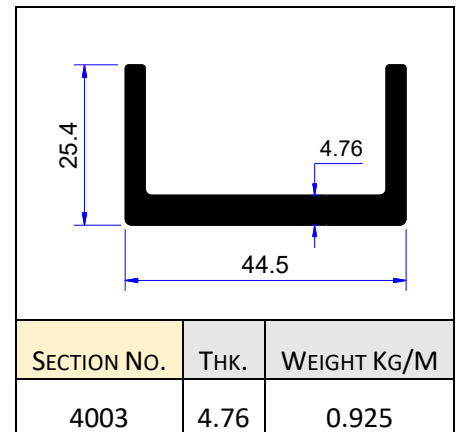
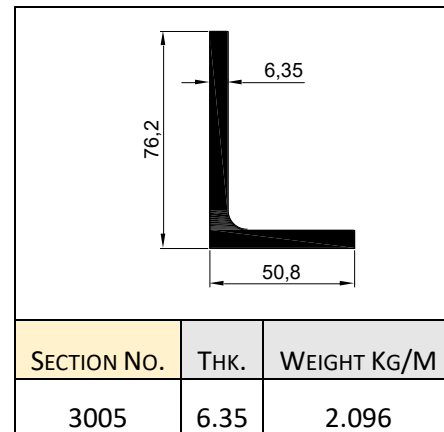
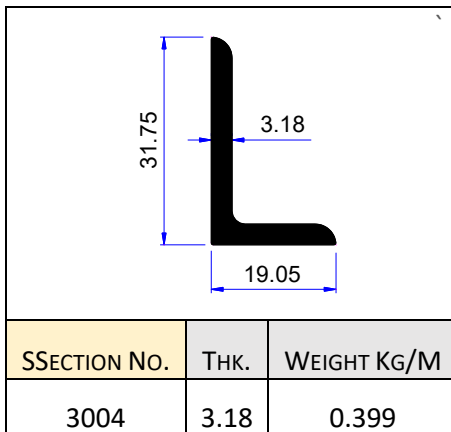
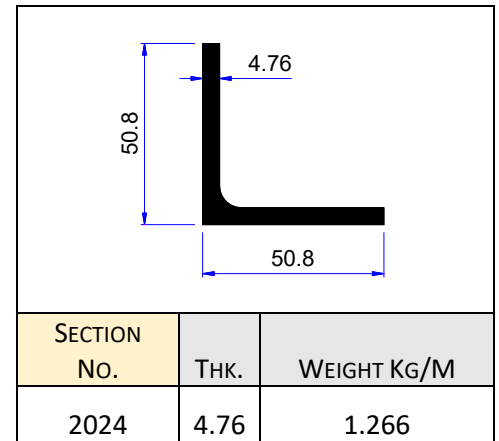
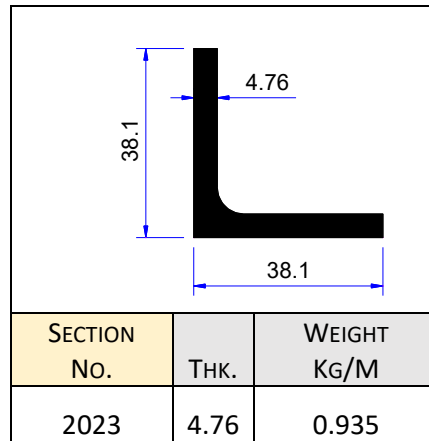
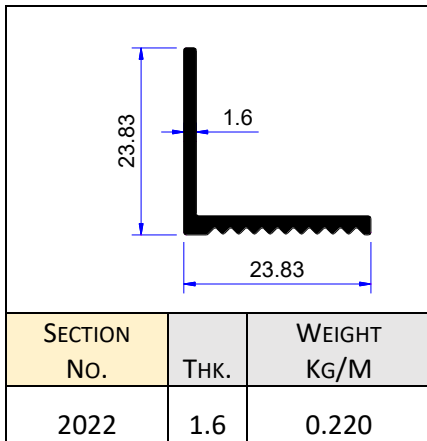
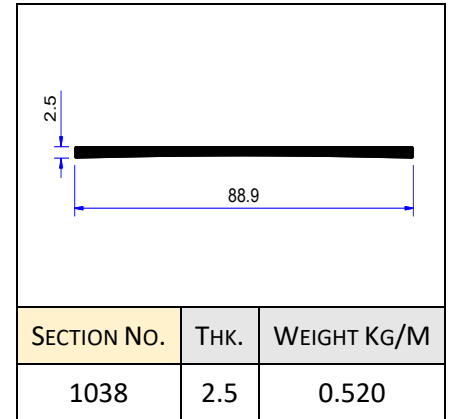
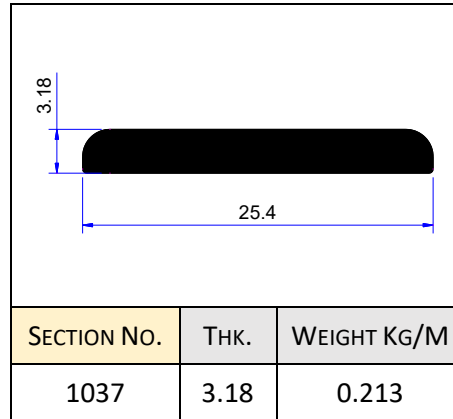
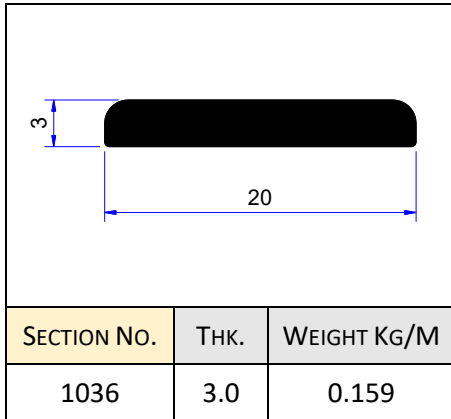

# TRANSPORT SECTION

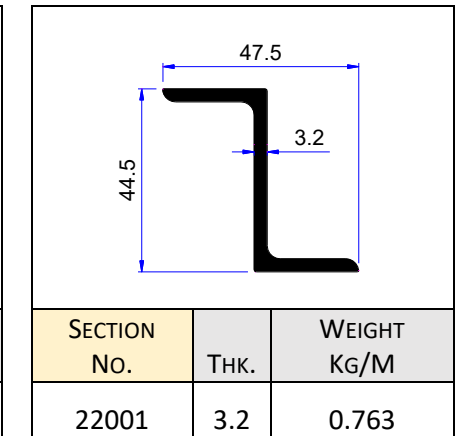
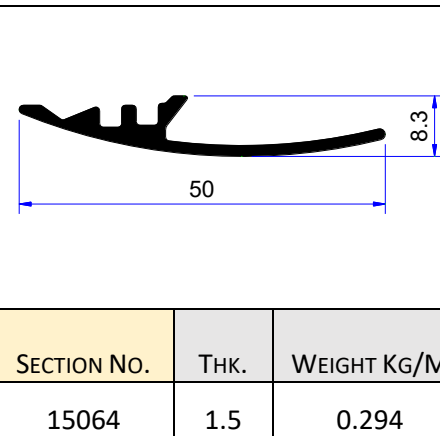
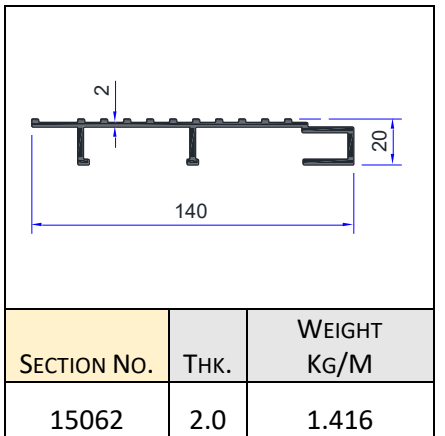
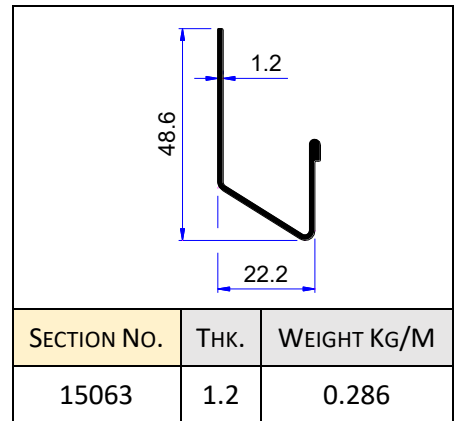
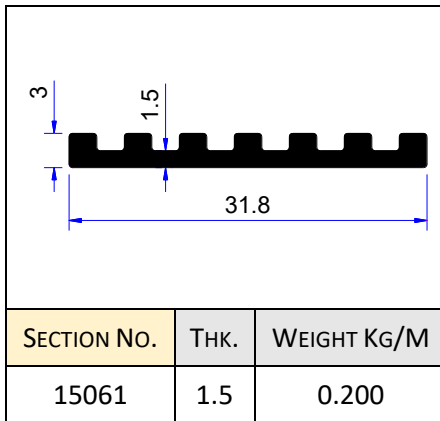
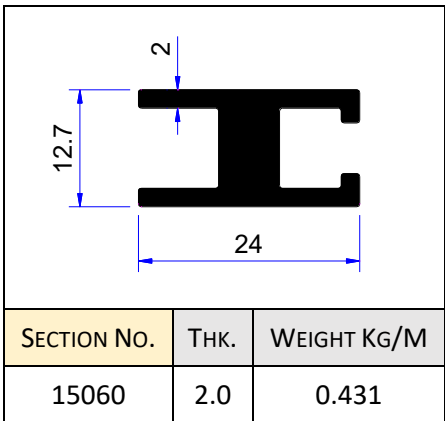
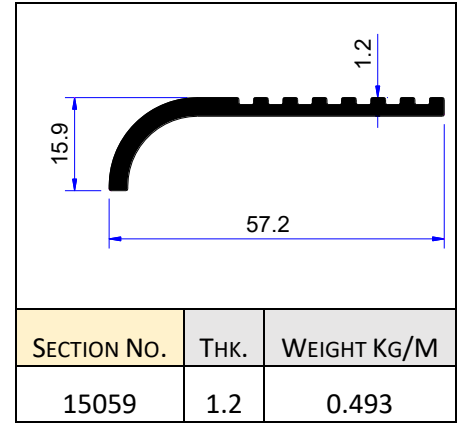
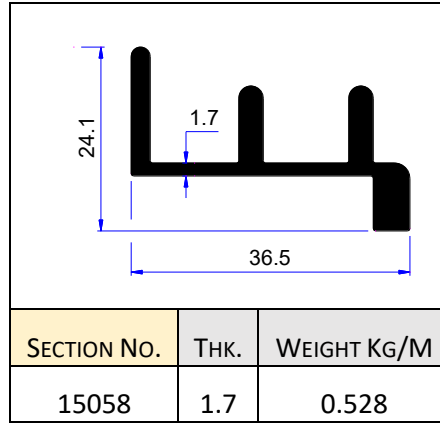
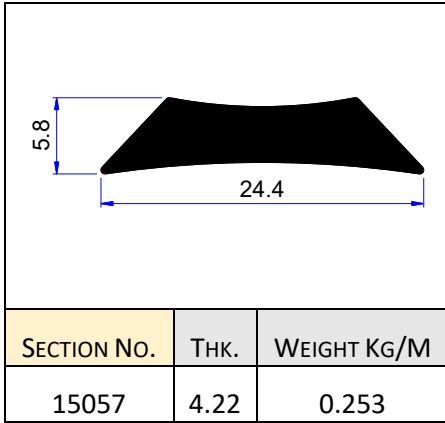

## SOLAR SECTIONS

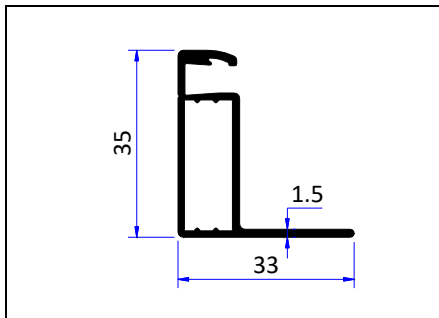

SECTION NO.	THK.	WEIGHT KG/M
23001	1.5	0.415

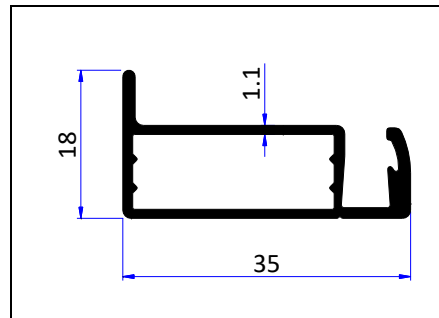

SECTION NO.	THK.	WEIGHT KG/M
23002	1.1	0.330

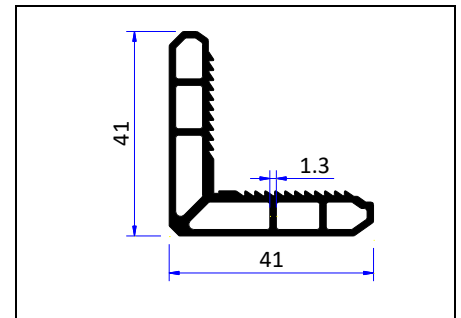

SECTION NO.	THK.	WEIGHT KG/M
23003	1.3	0.739

## ARCHITECTURAL MISCELLANEOUS.

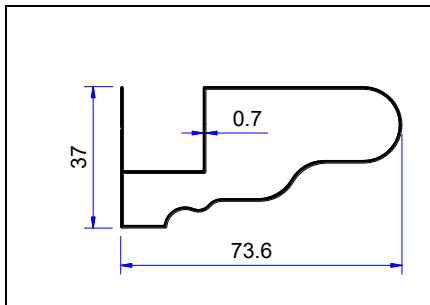

SECTION NO.	THK.	WEIGHT KG/M
17005	0.7	0.427

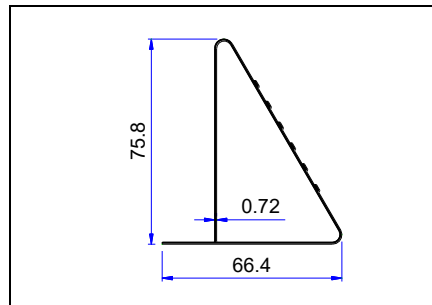

SECTION NO.	THK.	WEIGHT KG/M
17006	0.72	0.479

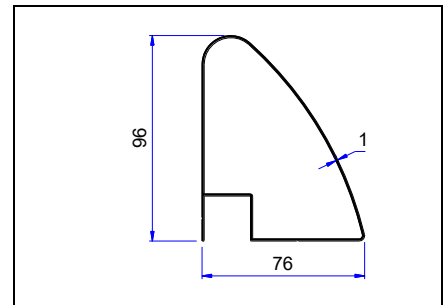

SECTION NO.	THK.	WEIGHT KG/M
17007	1.0	0.849

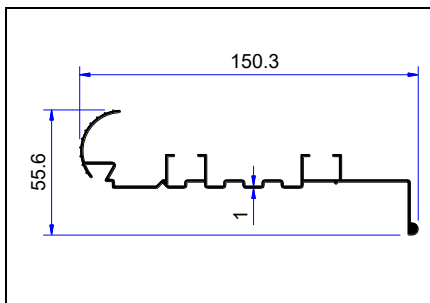

SECTION NO.	THK.	WEIGHT KG/M
18005	1.0	0.863

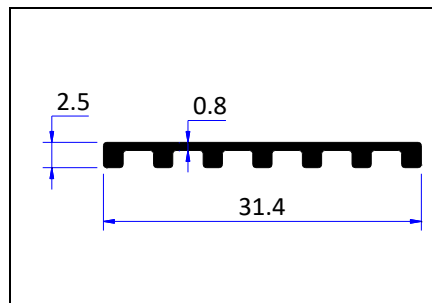

SECTION NO.	THK.	WEIGHT KG/M
15020	0.8	0.129

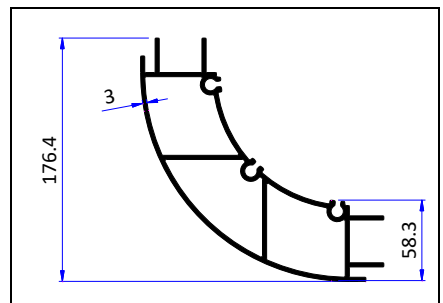

SECTION NO.	THK.	WEIGHT KG/M
14020	3.0	6.423

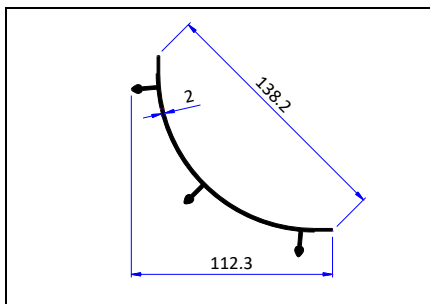

SECTION NO.	THK.	WEIGHT KG/M
15013	2.0	1.136

INDUSTRIAL MISCELLANEOUS

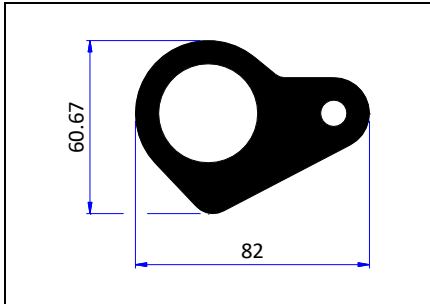

SECTION NO.	THK.	WEIGHT KG/M
17001	8.2	5.989

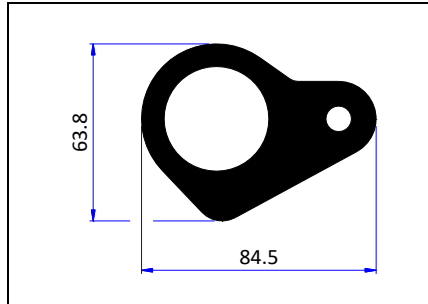

SECTION NO.	THK.	WEIGHT KG/M
17002	8.2	6.381

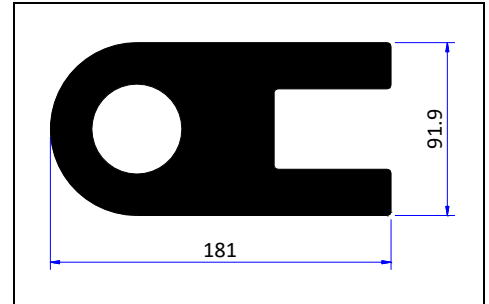

SECTION NO.	THK.	WEIGHT KG/M
17004	24.6	30.451

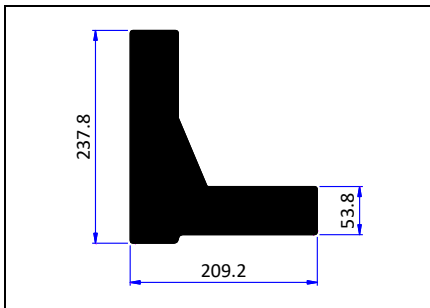

SECTION NO.	THK.	WEIGHT KG/M
18004	53.8	60.430

ACTUADORES

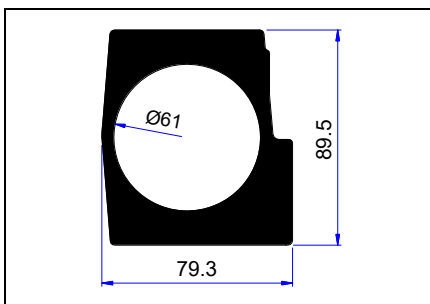

SECTION NO.	THK.	WEIGHT KG/M
17009	-	9.667

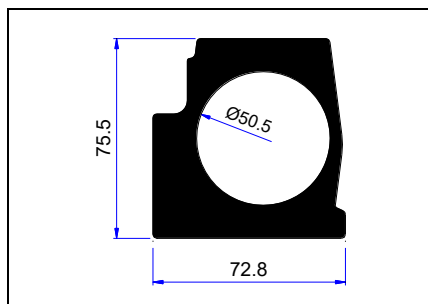

SECTION NO.	THK.	WEIGHT KG/M
17008	-	7.828

LADDER SECTION

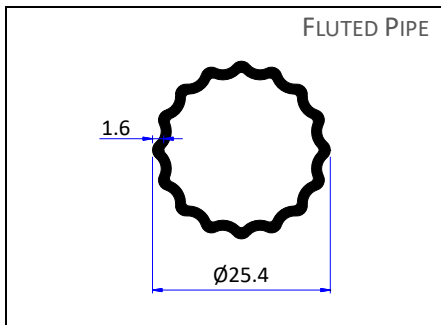

SECTION NO.	THK.	WEIGHT KG/M
10001	1.6	0.312

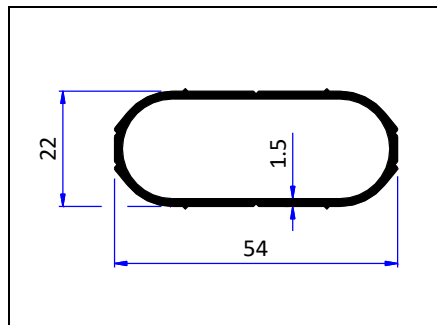

SECTION NO.	THK.	WEIGHT KG/M
10002	1.5	0.537

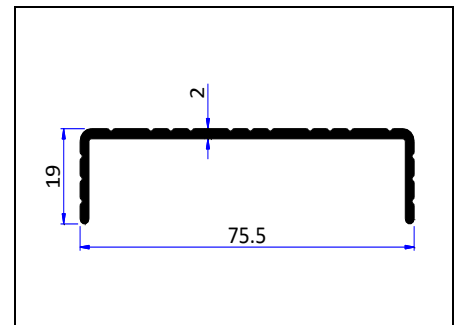

SECTION NO.	THK.	WEIGHT KG/M
10003	2.0	0.563

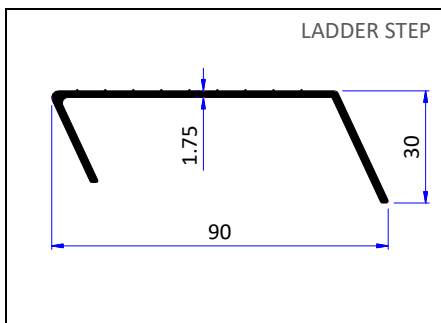

SECTION NO.	THK.	WEIGHT KG/M
10004	1.75	0.671

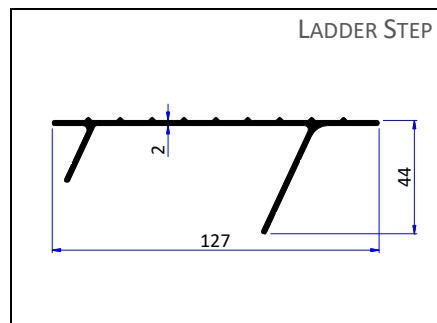

SECTION NO.	THK.	WEIGHT KG/M
10005	2.0	1.126

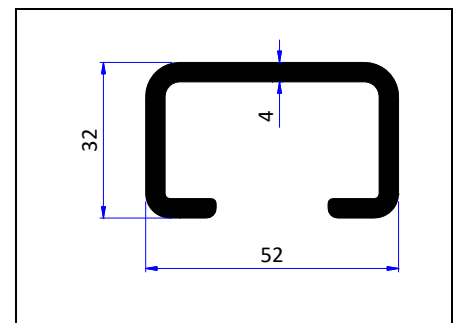

SECTION NO.	THK.	WEIGHT KG/M
10007	4.0	1.313

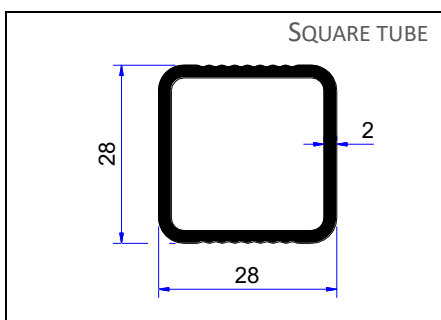

SECTION NO.	THK.	WEIGHT KG/M
10008	2.0	0.523

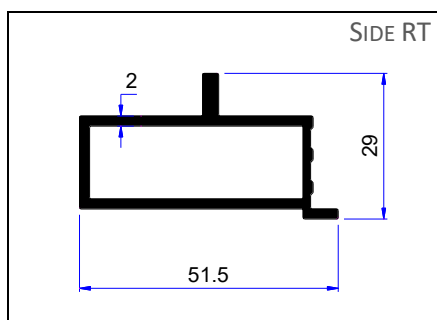

SECTION NO.	THK.	WEIGHT KG/M
10009	2.0	0.755

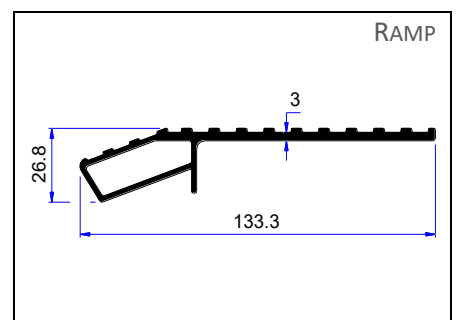

SECTION NO.	THK.	WEIGHT KG/M
10010	3.0	1.528

# LADDER SECTIONS

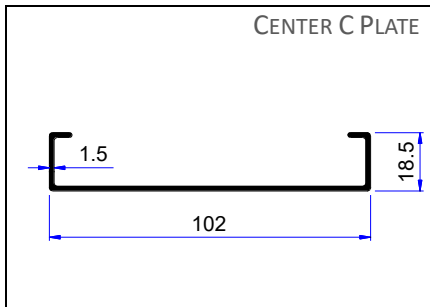

SECTION NO.	THK.	WEIGHT KG/M
10011	1.5	0.596

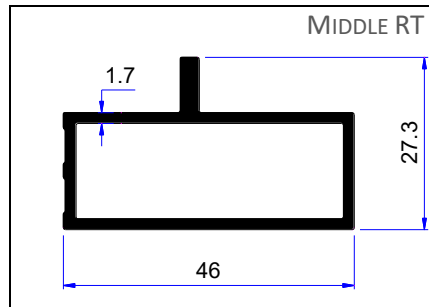

SECTION NO.	THK.	WEIGHT KG/M
10014	1.7	0.635

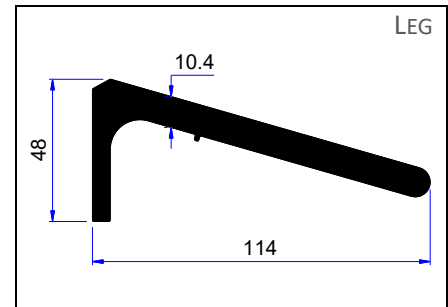

SECTION NO.	THK.	WEIGHT KG/M
10015	10.4	3.86

# CURTAIN WALLS

## TENT PROFILE

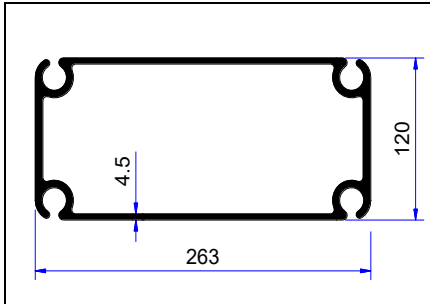

SECTION NO.	THK.	WEIGHT KG/M
14116	4.5	11.844

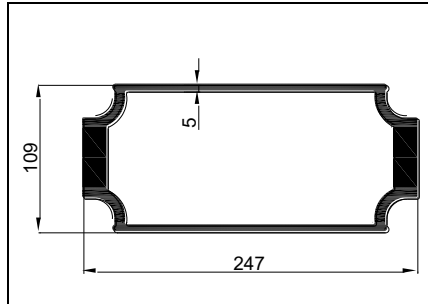

SECTION NO.	THK.	WEIGHT KG/M
14117	5.0	13.475

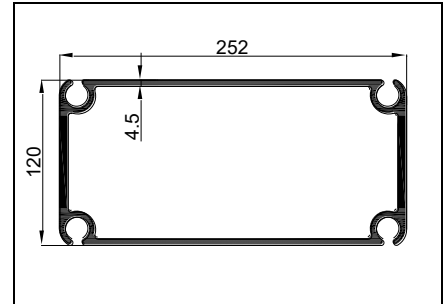

SECTION NO.	THK.	WEIGHT KG/M
14118	4.5	10.391

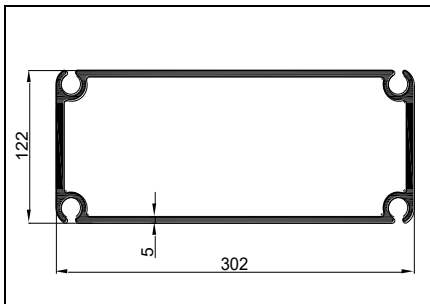

SECTION NO.	THK.	WEIGHT KG/M
14119	5.0	12.558

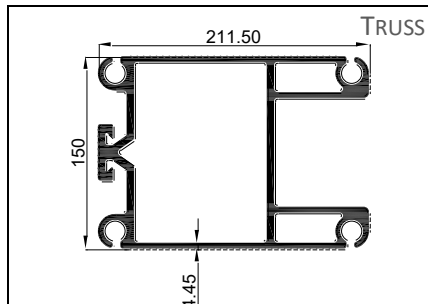

SECTION NO.	THK.	WEIGHT KG/M
14129	4.45	14.697

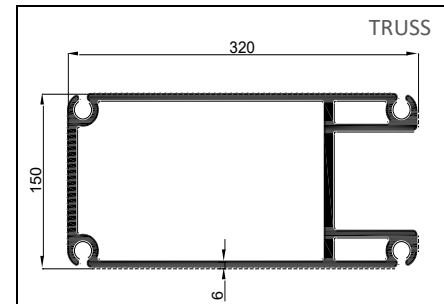

SECTION NO.	THK.	WEIGHT KG/M
14130	6.0	20.924

# CURTAIN WALLS

## CURTAIN WALLS

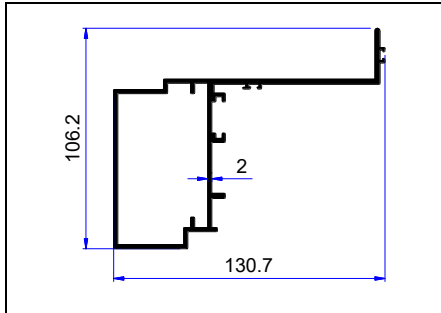

SECTION NO.	THK.	WEIGHT KG/M
14028	2.0	2.347

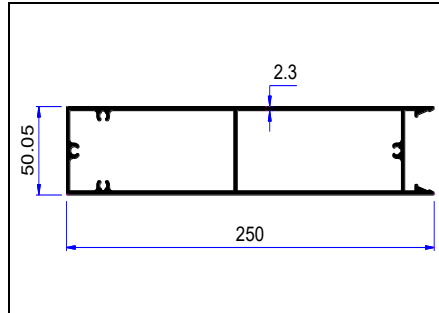

SECTION NO.	THK.	WEIGHT KG/M
14077	2.3	4.371

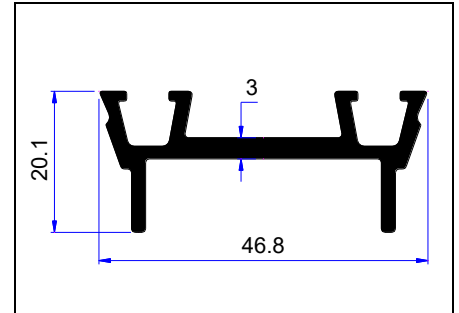

SECTION NO.	THK.	WEIGHT KG/M
15065	3.0	0.600

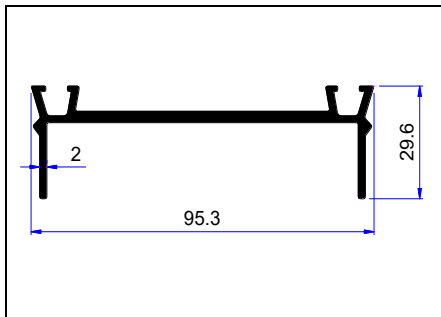

SECTION NO.	THK.	WEIGHT KG/M
15066	2.0	1.107

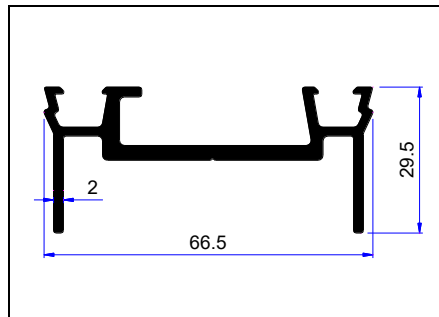

SECTION NO.	THK.	WEIGHT KG/M
15067	2.0	0.960

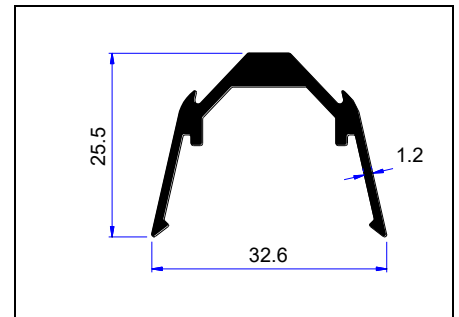

SECTION NO.	THK.	WEIGHT KG/M
15082	1.2	0.367

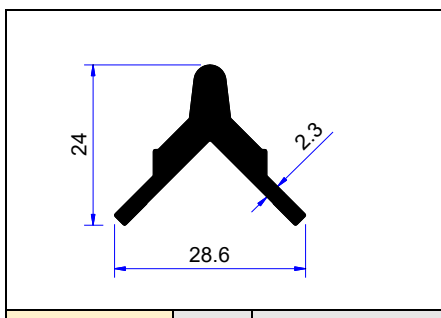

SECTION NO.	THK.	WEIGHT KG/M
15081	2.3	0.464

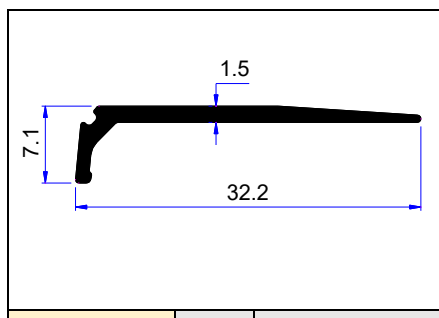

SECTION NO.	THK.	WEIGHT KG/M
15100	1.5	0.133

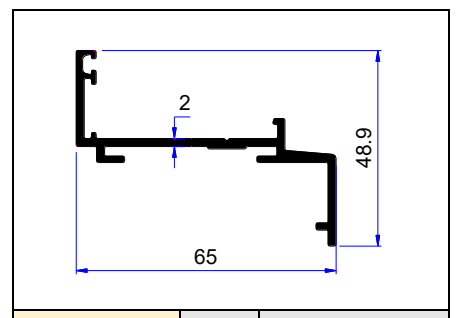

SECTION NO.	THK.	WEIGHT KG/M
15101	2.0	0.774

# CURTAIN WALLS

## 120 mm Curtain Walls

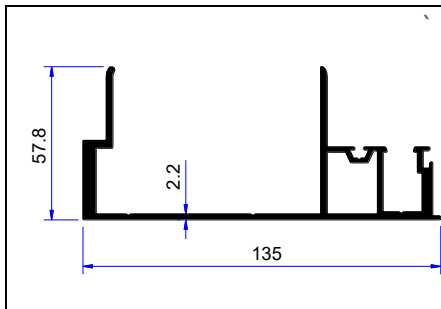

SECTION NO.	THK.	WEIGHT KG/M
14131	2.2	2.368

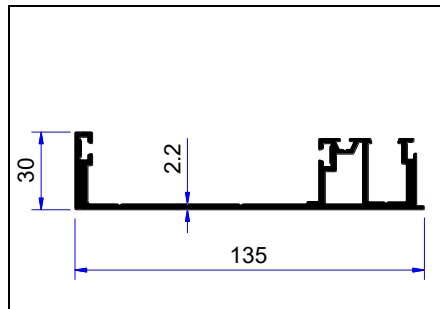

SECTION NO.	THK.	WEIGHT KG/M
14132	2.2	1.931

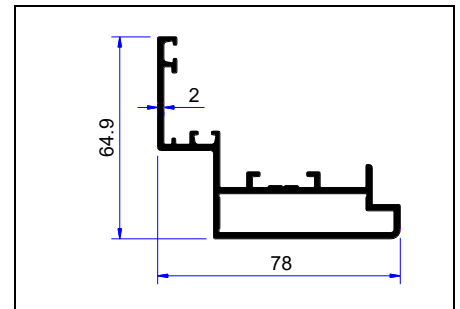

SECTION NO.	THK.	WEIGHT KG/M
14133	2.0	1.356

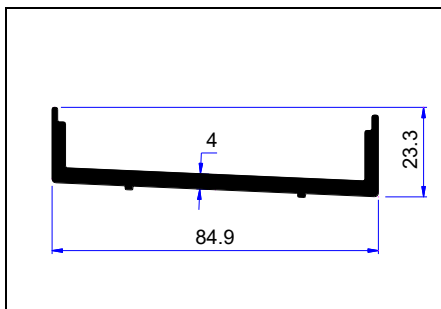

SECTION NO.	THK.	WEIGHT KG/M
15102	4.0	1.196

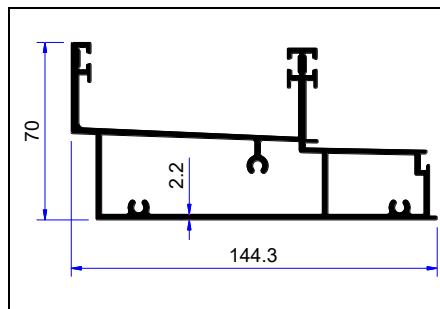

SECTION NO.	THK.	WEIGHT KG/M
14134	2.2	3.211

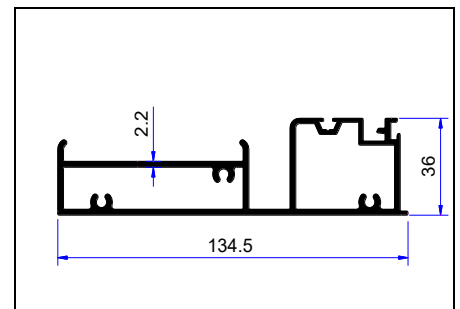

SECTION NO.	THK.	WEIGHT KG/M
14135	2.2	2.425

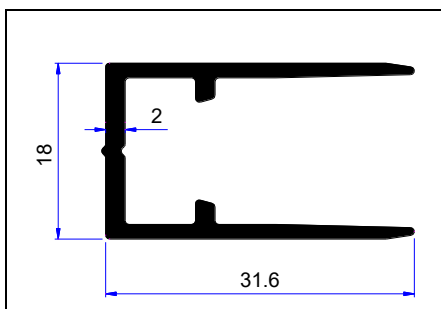

SECTION NO.	THK.	WEIGHT KG/M
15103	2.0	0.346

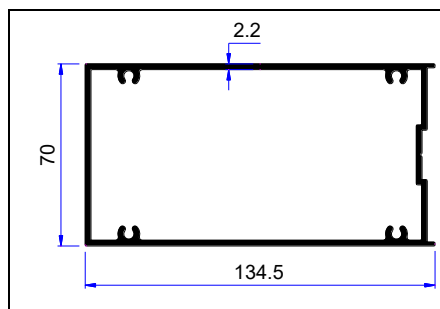

SECTION NO.	THK.	WEIGHT KG/M
14136	2.2	2.676

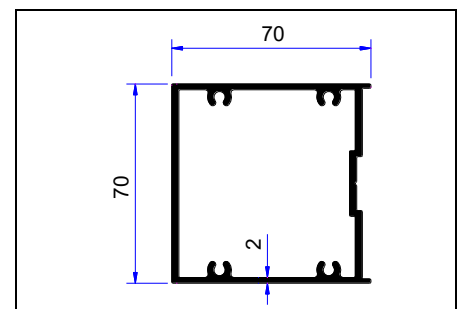

SECTION NO.	THK.	WEIGHT KG/M
14137	2.0	1.965

# CURTAIN WALLS

## Sleek Curtain Walls

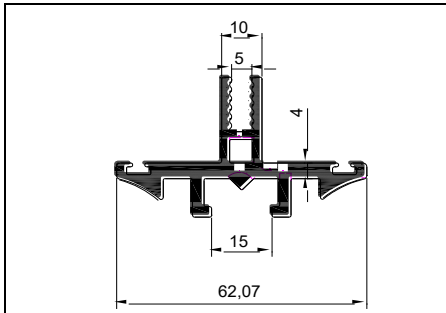

SECTION NO.	THK.	WEIGHT KG/M
14126	2.8	1.224

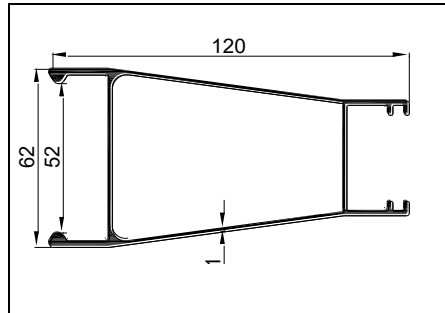

SECTION NO.	THK.	WEIGHT KG/M
14127	1.0	1.247

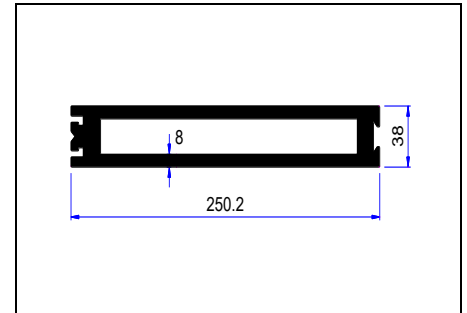

SECTION NO.	THK.	WEIGHT KG/M
14128	8.0	12.855

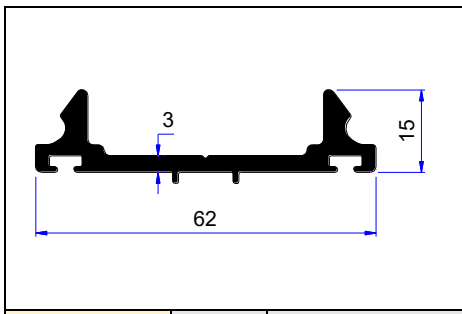

SECTION NO.	THK.	WEIGHT KG/M
15099	3.0	0.778

CURTAIN WALLS  
186 mm Curtain series

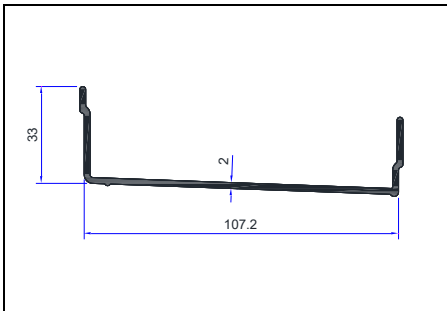

SECTION NO.	THK.	WEIGHT KG/M
15090	2.0	0.890

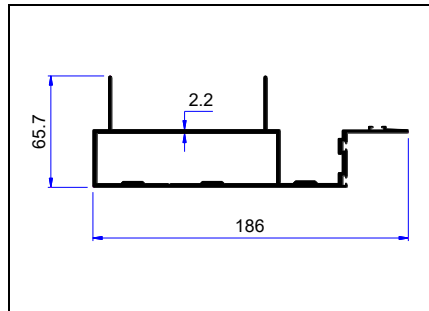

SECTION NO.	THK.	WEIGHT KG/M
14098	2.2	2.923

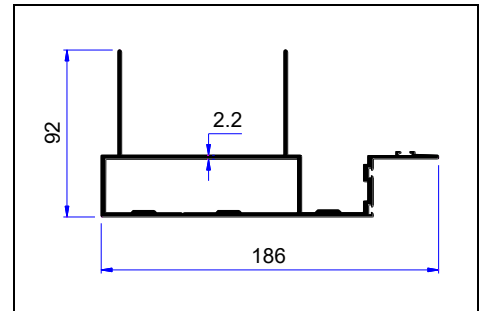

SECTION NO.	THK.	WEIGHT KG/M
14099	2.2	3.208

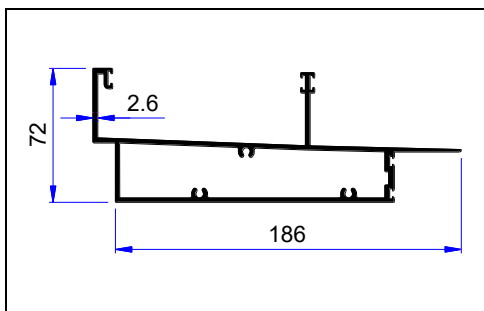

SECTION NO.	THK.	WEIGHT KG/M
14100	2.6	3.422

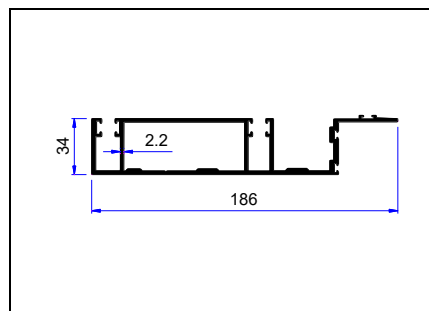

SECTION NO.	THK.	WEIGHT KG/M
14101	2.2	2.910

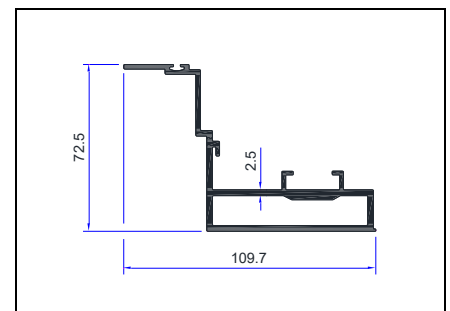

SECTION NO.	THK.	WEIGHT KG/M
14102	2.5	1.946

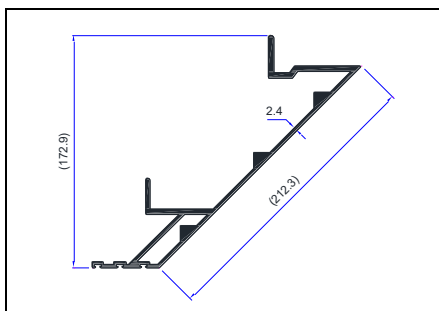

SECTION NO.	THK.	WEIGHT KG/M
14103	2.4	4.417

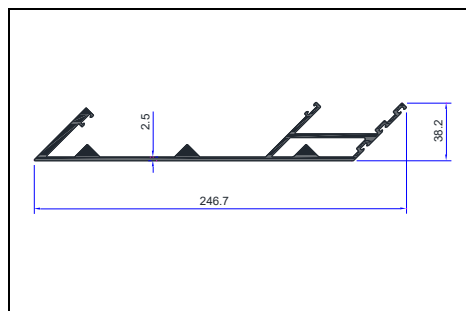

SECTION NO.	THK.	WEIGHT KG/M
14104	2.5	3.594

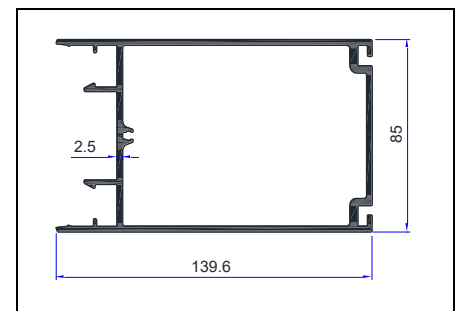

SECTION NO.	THK.	WEIGHT KG/M
14105	2.5	3.496

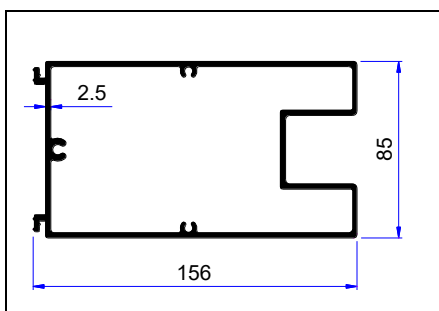

SECTION NO.	THK.	WEIGHT KG/M
14106	2.5	4.617

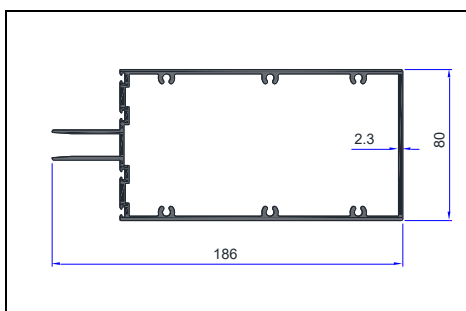

SECTION NO.	THK.	WEIGHT KG/M
14107	2.3	3.685

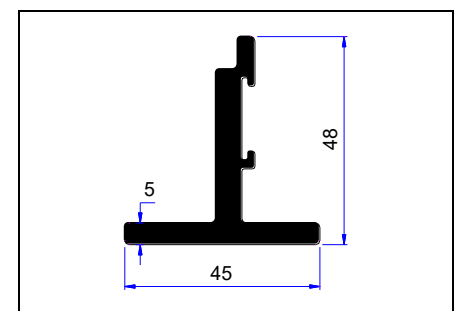

SECTION NO.	THK.	WEIGHT KG/M
15086	5.0	1.310

# CURTAIN WALLS

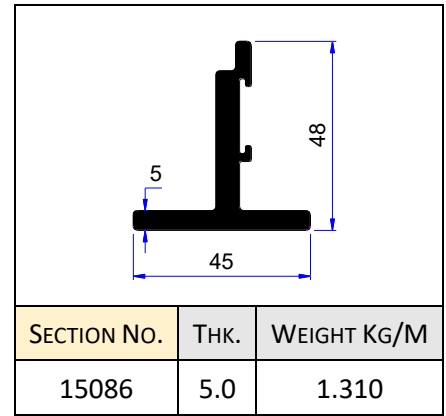
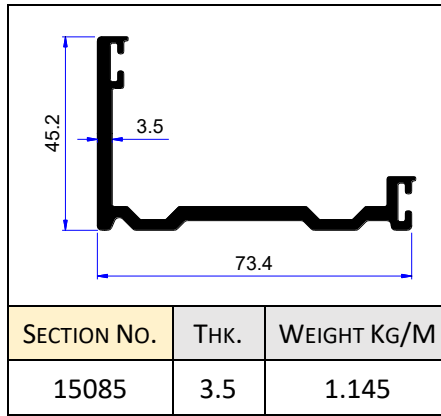
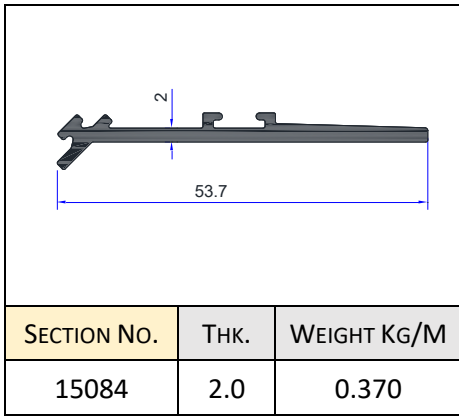

## Semi-Unitised Curtain Walls

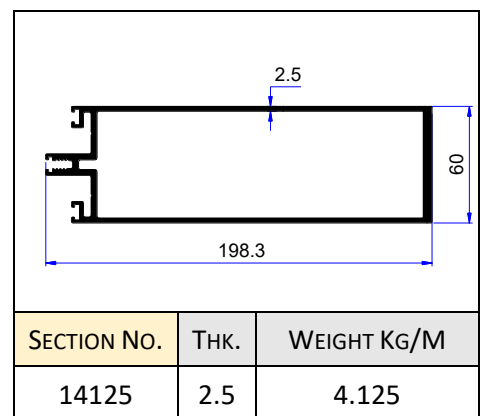
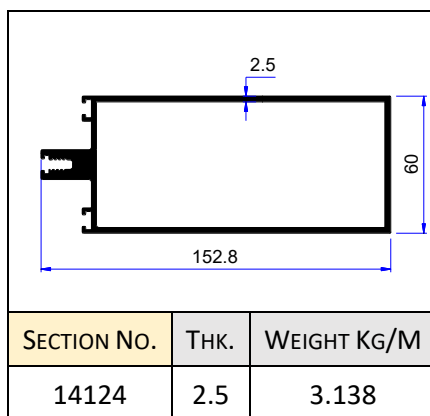
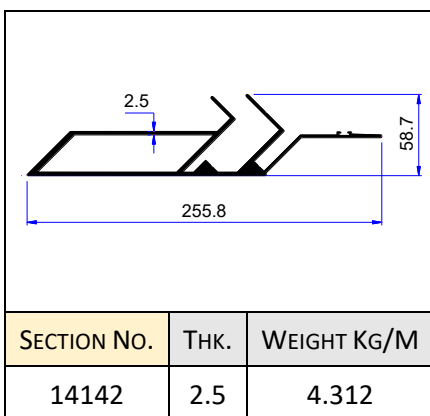
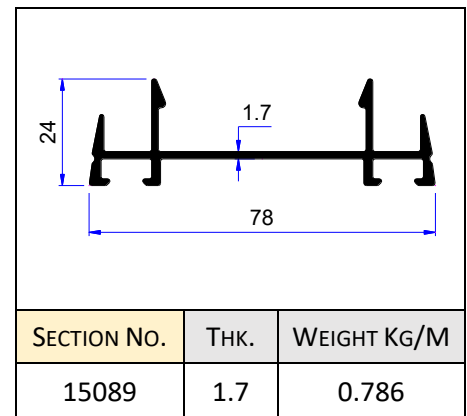
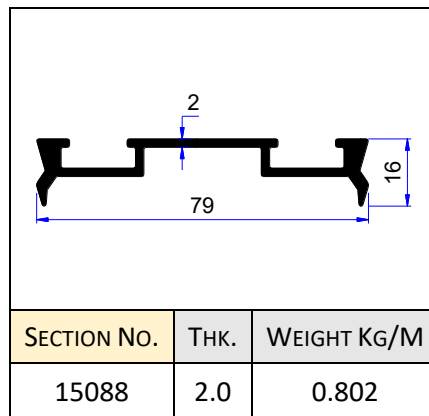
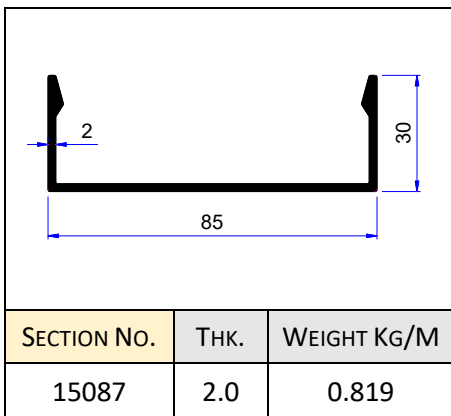

# CURTAIN WALLS

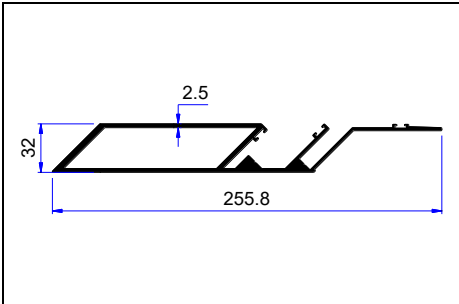

SECTION NO.	THK.	WEIGHT KG/M
14141	2.5	3.737

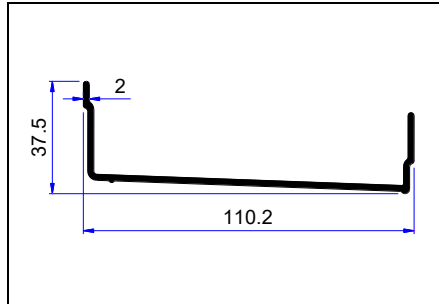

SECTION NO.	THK.	WEIGHT KG/M
15090	2.0	0.890

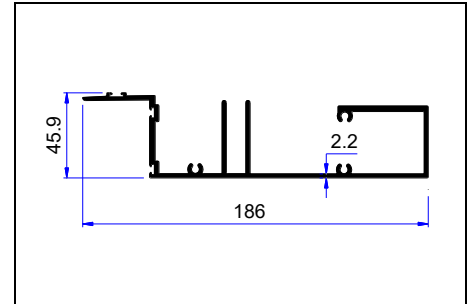

SECTION NO.	THK.	WEIGHT KG/M
15091	2.2	2.776

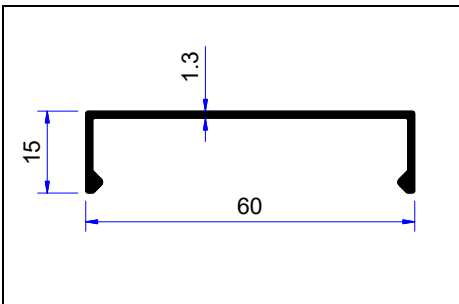

SECTION NO.	THK.	WEIGHT KG/M
15097	1.3	0.33

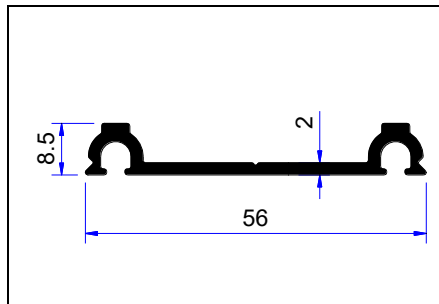

SECTION NO.	THK.	WEIGHT KG/M
15098	2.0	0.420

## BRACKETS

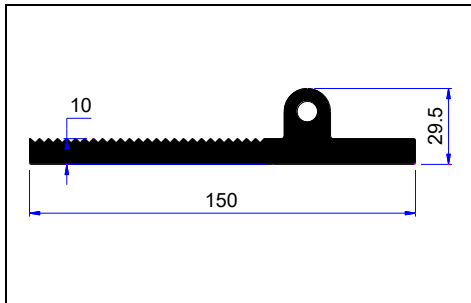

SECTION NO.	THK.	WEIGHT KG/M
14097	10.0	4.737

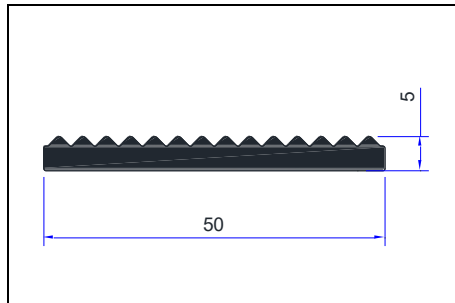

SECTION NO.	THK.	WEIGHT KG/M
15083	5.0	0.582

## FORM WORK

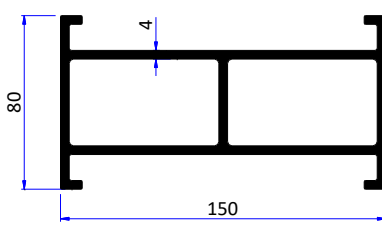

SECTION NO.	THK.	WEIGHT KG/M
14016	4.0	5.508

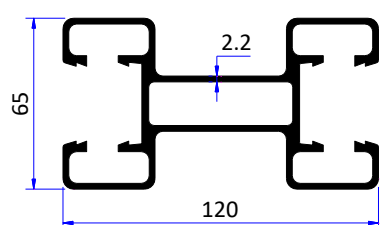

SECTION NO.	THK.	WEIGHT KG/M
14017	2.2	3.412

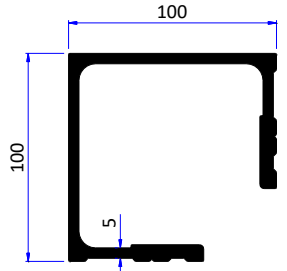

SECTION NO.	THK.	WEIGHT KG/M
15037	5.0	4.878

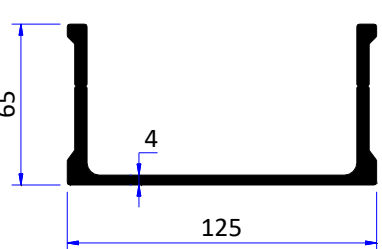

SECTION NO.	THK.	WEIGHT KG/M
15038	4.0	3.254

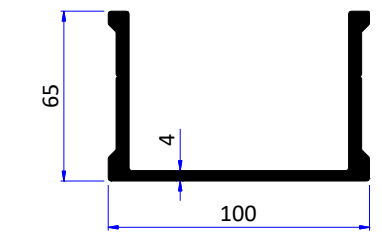

SECTION NO.	THK.	WEIGHT KG/M
15039	4.0	2.934

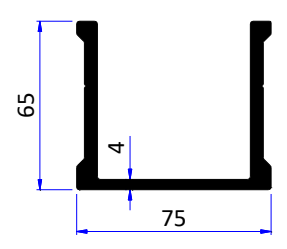

SECTION NO.	THK.	WEIGHT KG/M
15040	4.0	2.664

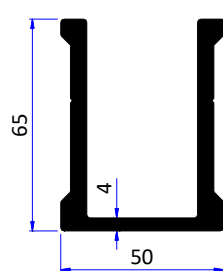

SECTION NO.	THK.	WEIGHT KG/M
15041	4.0	2.394

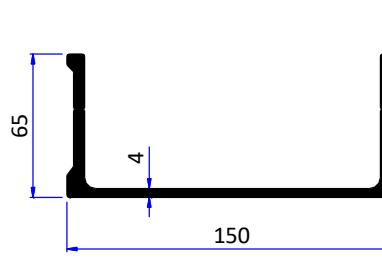

SECTION NO.	THK.	WEIGHT KG/M
15042	4.0	3.524

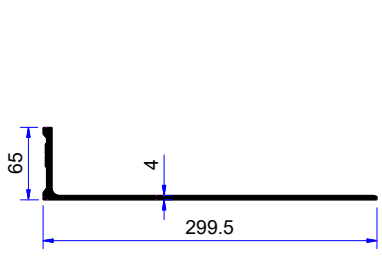

SECTION NO.	THK.	WEIGHT KG/M
3006	4.0	4.234

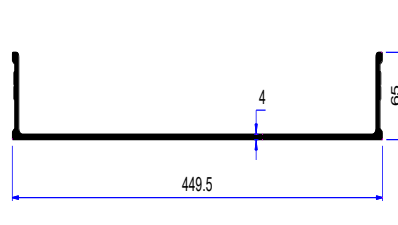

SECTION NO.	THK.	WEIGHT KG/M
15109	4.0	6.798

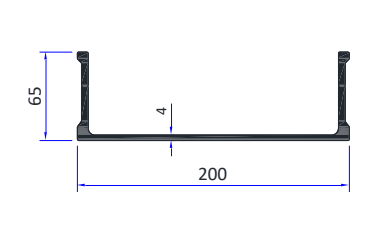

SECTION NO.	THK.	WEIGHT KG/M
15043	4.0	4.064

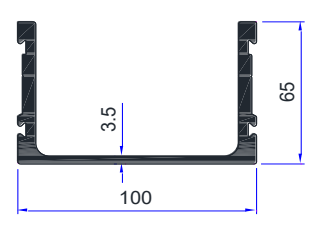

SECTION NO.	THK.	WEIGHT KG/M
15049	3.5	2.978

# FORMWORK SECTIONS

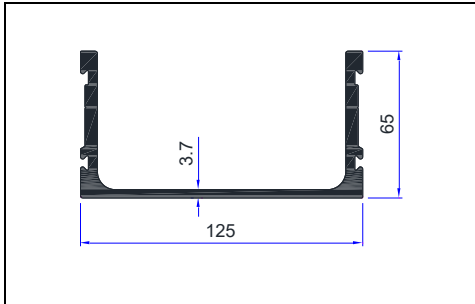

SECTION NO.	THK.	WEIGHT KG/M
15050	3.7	3.306

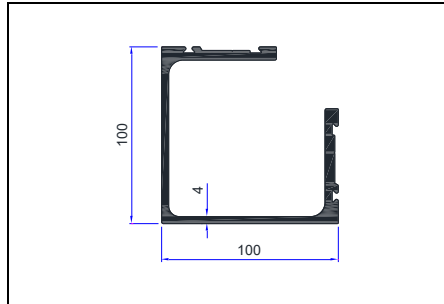

SECTION NO.	THK.	WEIGHT KG/M
15051	4.0	4.183

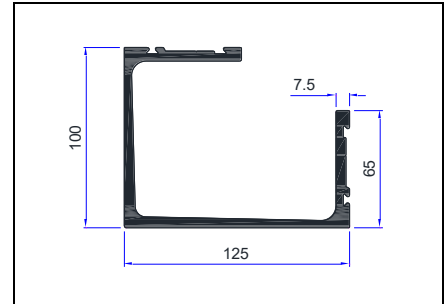

SECTION NO.	THK.	WEIGHT KG/M
15052	7.5	4.987

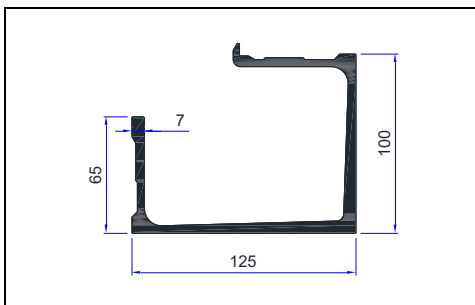

SECTION NO.	THK.	WEIGHT KG/M
15053	7.0	5.114

## CERTIFICATIONS

Bureau Veritas Certification



**Certificate of Approval**  
AWARDED TO  
**VARRON AUTOKAST LIMITED**  
KH. NO. 174, 175, 176/1, 176/2, 185, 186/2, 188, 189, 191, 196, 201/2, 201/3, 201/5,  
MOUZA - CHIMNAZARI, CHANDRAPUR ROAD, NAGPUR - 441108, Maharashtra, India  
IATF USI: 6E5WC4

Bureau Veritas Certification certify that the Quality Management System of the above organisation has been audited and found to be in accordance with the requirements of

**IATF 16949 - FIRST EDITION**  
and the applicable customer specific requirements



SCOPE  
Manufacturing  
PERMITTED EXCLUSION(S)  
8.3 - Design and development of products and services  
PRODUCT(S) DELIVERED  
ALUMINIUM ALLOY INGOTS, STEEL FORGED COMPONENTS,  
MACHINED COMPONENTS & ALUMINIUM EXTRUDED PRODUCTS

Date Of Certification: 05 November 2024  
Date Of Expiration: 04 November 2027  
IATF Certificate N° : 0553704  
Bureau Veritas Certification Certificate No: IN048968 - IATF Revision: 1

For Bureau Veritas Certification Holding, Tour ALTO, 4 place des saisons, 92400 COURBEVOIE - France  
(The official document is in English. Any translations of this document shall be used for reference only.)

1/1



Scan For E-Copy  
of Product Catalogue.



Bureau Veritas Certification



**VARRON AUTOKAST LIMITED**

KH. NO. 174, 175, 176/1, 176/2, 185, 186/2, 188, 189, 191, 196, 201/2, 201/3, 201/5,  
MOUZA - CHIMNAZARI, CHANDRAPUR ROAD, NAGPUR - 441108, MAHARASHTRA, INDIA.

*Bureau Veritas Certification Holding SAS – UK Branch certifies that the Management System of the above organisation has been audited and found to be in accordance with the requirements of the Management System Standard detailed below.*

---

Standard

ISO 9001:2015

---

Scope of certification

MANUFACTURING OF  
ALUMINIUM ALLOY INGOTS, STEEL FORGED COMPONENTS,  
MACHINED COMPONENTS & ALUMINIUM EXTRUDED PRODUCTS



Original cycle start date: **27 November 2024**  
Certification cycle start date: **27 November 2024**  
Subject to the continued satisfactory operation of the organisation's Management System, this certificate is valid until: **04 November 2027**  
Certificate No. **IND.24.62/QM/U**    Version: **1**    Issue date: **27 November 2024**

For certificate authenticity, click here  
<https://certcheck.ukas.com/>



Signed on behalf of BVCH SAS UK Branch  
**Jagdish N. MANIAN**  
Director – CERTIFICATION, South Asia  
Commodities, Industry & Facilities Division



Certification body address: 8th Floor, 100 Lower Thames Street, London, EC3R 6DL, United Kingdom.  
Local office: Bureau Veritas (India) Private Limited (Certification Business),  
72 Business Park, Marol Industrial Area, MIDC Cross Road "C",  
Andheri (East), Mumbai - 400 093, India.

Further clarifications regarding the scope of this certificate and the applicability of the management system requirements may be obtained by consulting the organisation.  
To check this certificate validity please call + 91 22 6574 2000.



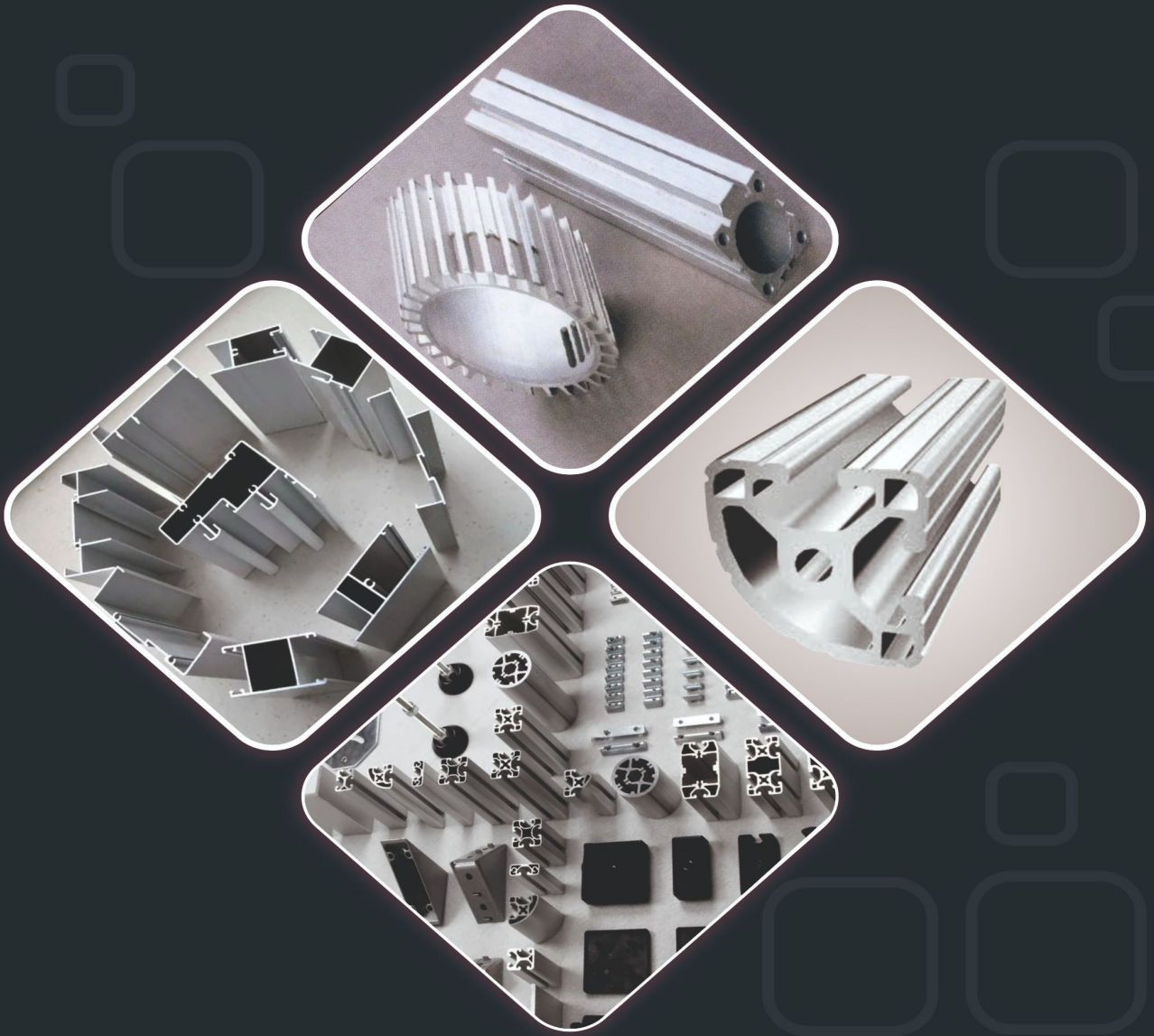

For Company  
Profile



## Work

- 📍 Kh. No. 174, Chimnazari, Chandrapur Road, Nagpur - 441 108, (MH), India.

## Registered Office

- 📍 9, Late Shri. Puranlalji Agrawal Road (Formerly Imambada Road), Nagpur.
- ☎ +91-9862298622

- ✉ info@sanvijay.com
- ✉ aluminium@sanvijay.com
- 🌐 www.sanvijay.com